

Rev.	ECN Number	Description	Drawn/Date
1	EH17030030	First Issue	Rain Zhou_2016/08/20

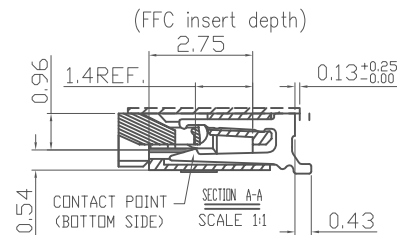
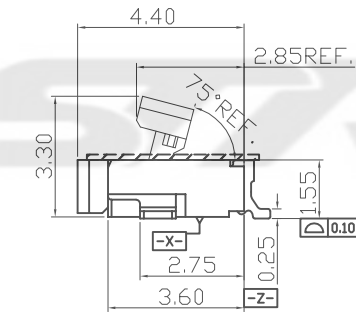
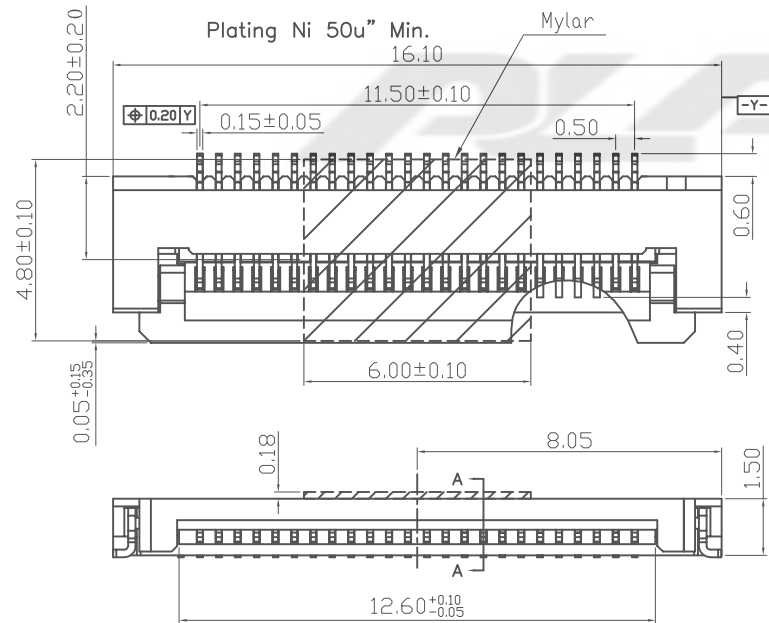
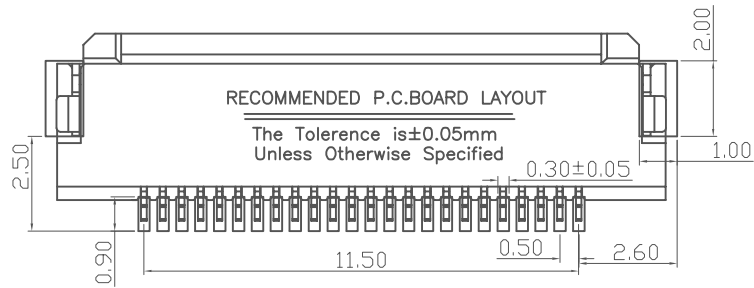
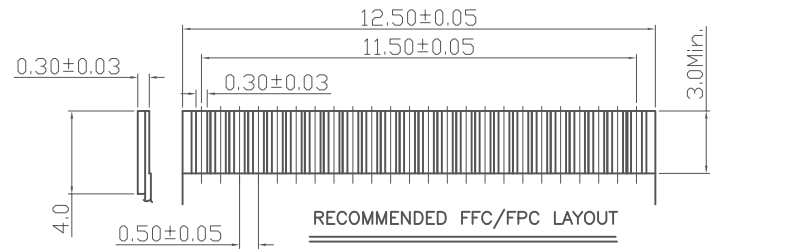

Notes: (Unless otherwise specified)

1. Dimension shall be interpreted per ANSI Y14.5M.
2. Contact retention force: 100g Min. per contact.
3. The FFC/FPC withdraw force: 25g Min. per contact.
4. Current rating: 0.5 AMPERE.
5. Contact resistance: 20 m ohms MAX. for initial.
6. Dielectric withstanding voltage: 500V AC rms. per one minute.
7. Insulation resistance: 100 M ohms Min.
8. Harmful material should be compliant to doc."EI-0005" standards.
9. Product number matrix:

FZ26-24 W C-60-H  
 pos. no. | W | C | 60 | H  
 H: Halogen free  
 C: Reel+Mylar

Contact & Solder Plating Type  
 W: Plating Matte Tin 100u" Min.  
 Plating Ni 50u" Min.

**FOR HUAWEI USE ONLY**

HUA WEI CODE	1406G002
PLA P/N	FZ26-24WC-60-H



PLASTREN TECHNOLOGY (SHEN ZHEN) CO., LTD.

GENERAL TOLERANCE		SCALE	ORIGINAL DRAWN	DATE	DWG. NO.	TITLE	REV.
XX. ± 0.40	XXX. ±	5:1	Rain Zhou	2016/08/20	600-0000-1566	CUSTOMER DRAWING	1
X. ± 0.30	.XXX ±	UNIT	Gavin Gao	2016/08/20			1
.X ± 0.20	X.* ± 3'	MM	APPROVE	DATE	PARTS NO.(INTENDED USE)		SHEET
.XX ± 0.10	.X* ± 2'	SIZE A4	NingJing Zhu	2016/08/20	FZ26-24WC-60-H		1/4

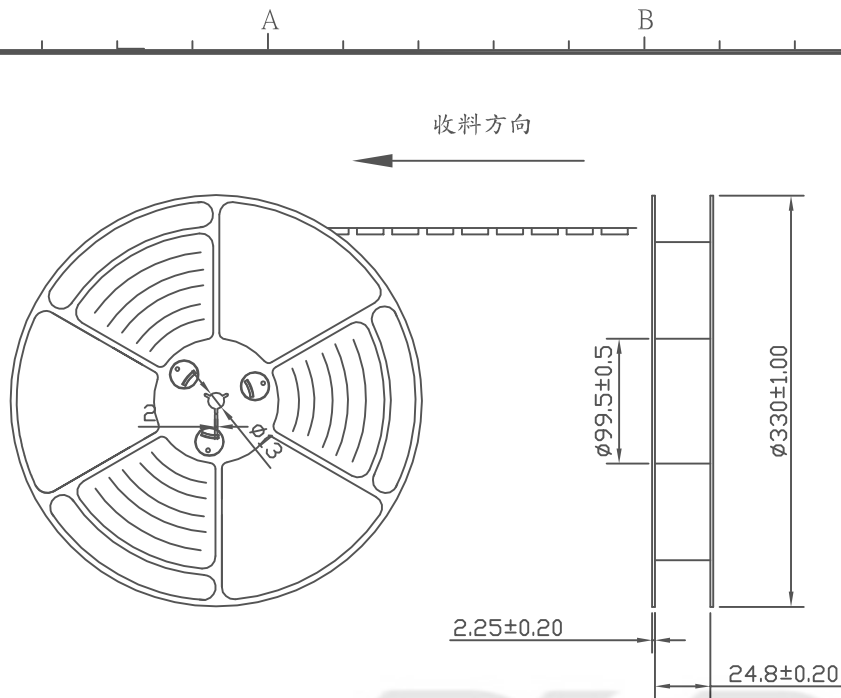

標籤黏貼處 (朝卷裝包材的小定位孔一側)  
 Location of label sticking (label at small positioning hole of the carrier tape side).

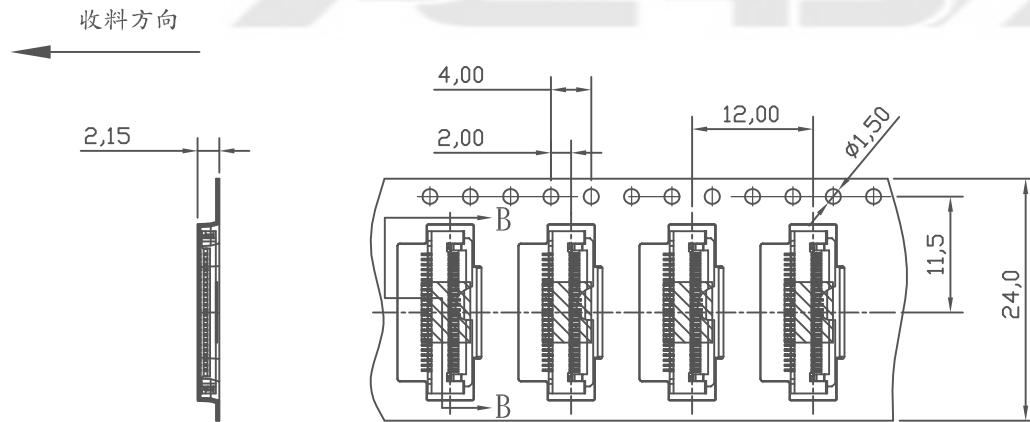
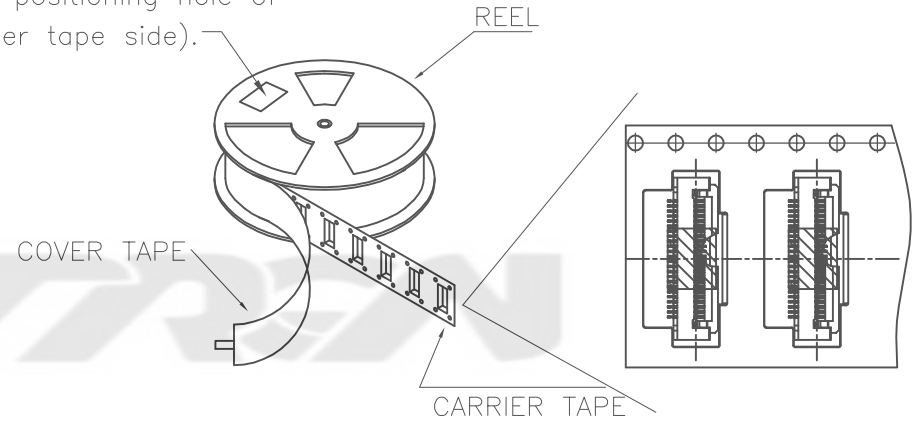

GENERAL TOLERANCE		SCALE	1:0.75	ORIGINAL DRAWN	Rain Zhou	DATE	2016/08/20	DWG. NO.	600-0000-1566	TITLE	CUSTOMER DRAWING	REV.	1
XX. ± 0.40	XXX. ±	UNIT	MM	CHECK	Gavin Gao	DATE	2016/08/20					PARTS NO.(INTENDED USE)	FZ26-24WC-60-H
X. ± 0.30	.XXX ±	SIZE	A4	APPROVE	NingJing Zhu	DATE	2016/08/20						
.X ± 0.20	X.° ± 3°												
.XX ± 0.10	.X.° ± 2°												



將標籤貼於紙箱側上方。

Stick the needful label On the up-right corner of the side of carton.

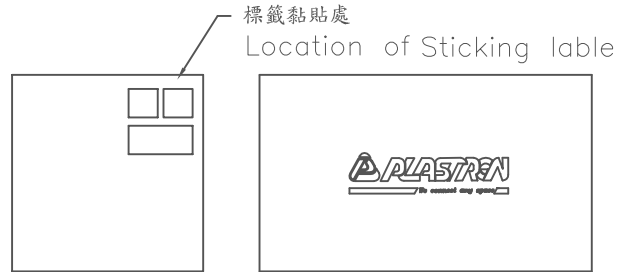

備註(REMARK)

1. 若有未裝滿之零數箱, 必須以緩衝材塞滿。  
The unfilling-carton must be filled with assuagement.
2. 包裝材料料號見下頁。  
The P/N of the packing material please follow next page.
3. 防水袋需用膠帶貼實且封口。  
Waterproof plastic bag must be folded up.
4. 裝滿成品后之外箱, 最大堆積箱數: 5箱  
About the box fully filled with products, the MAX accumulating quantity of boxes is 5.
5. 如須貼Bar-code, 請依Bar-code作業辦法執行  
If barcode lable is required,do it according to the related barcode lable operation standard

包裝明細表 (The detail of the packing)

材料名稱(name)	料號(P/N)	重量(N.W.,KG)	用量(Q'TY)
紙箱(Carton)	C018	0.543	1 Pcs
防水袋(PE Page)	080-0012-038	0.045	1 Pcs
珍珠棉(EPE)	080-0030-834	0.041	2 Pcs
Carrier Tape	051-0024-0066	-----	48M/Carton
軸心(Plastic Reel)	PR002	0.0400	7 Pcs
Cover Type	CTA002	0.0405	49M/Carton
防撞三角柱 (Anti-collision triangular prism)	051-0000-0103	0.0405	4 Pcs

PRODUCT No.	PACKING CAPACITY		
	PCS/REEL	REELS/CARTON	PCS/CARTON
FZ26-24WC-60-H	2500	7	17500

 PLASTRON TECHNOLOGY (SHEN ZHEN) CO., LTD.	GENERAL TOLERANCE		SCALE	1:0.75	ORIGINAL DRAWN	Rain Zhou	DATE	2016/08/20	DWG. NO.	600-0000-1566	TITLE	CUSTOMER DRAWING	REV.	1
	XX. ± 0.40	XXX. ±	UNIT	MM	CHECK	Gavin Gao	DATE	2016/08/20					PARTS NO.(INTENDED USE)	FZ26-24WC-60-H
	X. ± 0.30	.XXX ±	SIZE	A4	APPROVE	NingJing Zhu	DATE	2016/08/20						
	.X ± 0.20	X.* ± 3°												
.XX ± 0.10	.X.* ± 2°													