

A

B

C

D

E

版次	ECN 编码	描述		设计/日期
1	EL24060021	初版发行		江蒙_2024/06/01
		改前	改后	

NOTES: FINISH(PLATING THICKNESS IN MICRO-INCHES)

- 1.BRASS
- 2.STAINLESS STEEL
- 3.PASSIVATED
- 4.BERYLLIUM COPPER
- 5.NICKEL PL.100 MIN.THICK OVER COPPER PL.50 MIN.THICK
- 6.GOLD PL. 10 MIN.THICK OVER ELECTROLESS NICKEL PL. 100 MIN.THICK
- 7.ULTEM 1000

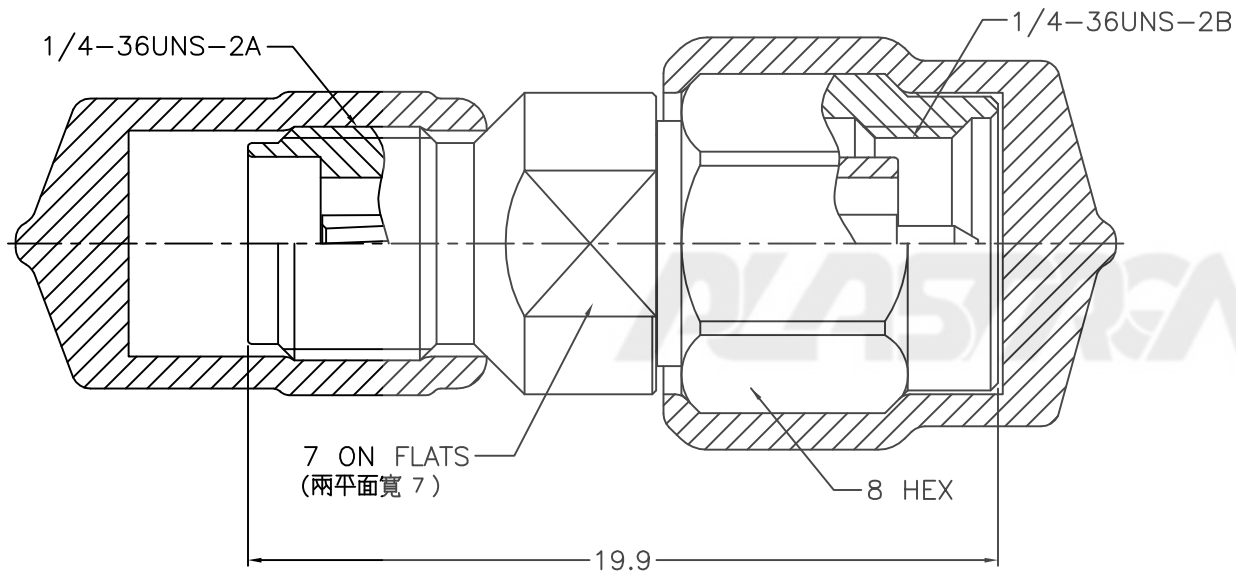

JFCNBCBXX

F:RF  
C:超小型  
N:3.5mm  
B:Beryllium Copper

A: Gold Flash  
G:10u"  
L:30u"  
B:Gold Plating

RoHS COMPLIANT



TOLERANCE TABLE	SCALE 2.5:1		DRAWN	江蒙	DATE	2024/06/01	DWG. NO. 600-0000-2466	TITLE 3.5mm PLUG TO JACK ADAPTOR CUSTOMER DRAWING	REV.	1
	X. ± 0.30	X.° ± 3°	CHECK	李晨涛	DATE	2024/06/01			SHEET	1/1
	.X ± 0.25	.X° ± 2°	SIZE A4	APPROVE	朱宁静	DATE	2024/06/01	PARTS NO.(INTENDED USE) JFCNBCBXX		
	.XX ± 0.20									

A

B

C

D

E