

版次	ECN 编码	描述		设计/日期
1	EL24050069	初版发行		江蒙_2024/05/28
		改前	改后	

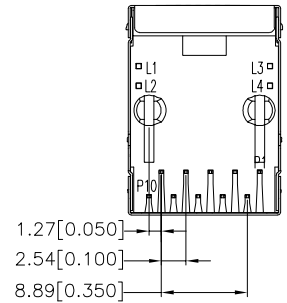

Emitting Color	$\lambda_p$ (nm)	$V_f$ @ $I_f=20mA$	$I_r$ @ $V_r=5V$
Green	568	1.7V~2.6V	10uA max
Yellow	588	1.7V~2.6V	10uA max

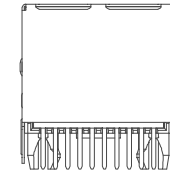
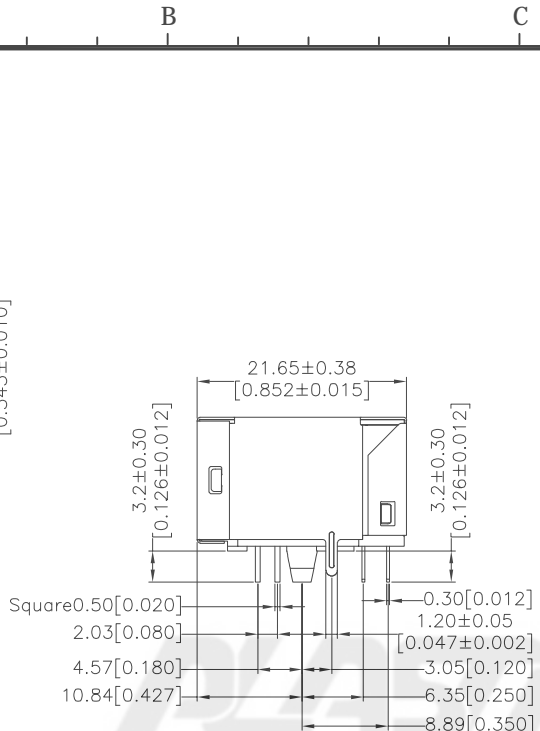
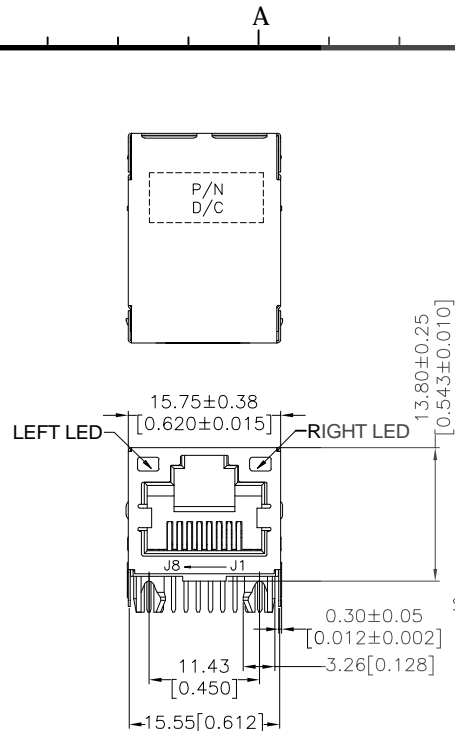
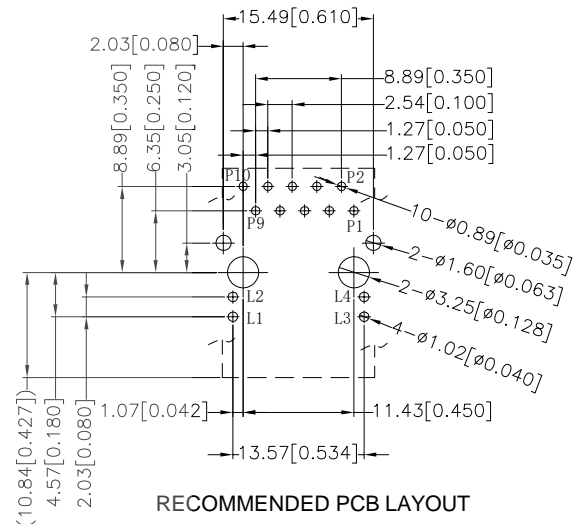

TOLERANCE TABLE	SCALE	2.5:1	DRAWN	江蒙	DATE	2024/05/28	DWG. NO.	TITLE	REV.
	X. ± 0.30	X.° ± 3°	CHECK	李晨涛	DATE	2024/05/28		600-0000-2452	
	.X ± 0.25	.X° ± 2°	APPROVE	朱宁静	DATE	2024/05/28	PARTS NO. (INTENDED USE)	CUSTOMER DRAWING	
	.XX ± 0.20		SIZE	A4			JAADAXDDXH		

**SPECIFICATONS:**

**1.MATERIAL**

- HOUSING:THERMOPLASTIC,UL 94V-0 , PA6T,BLACK,HSF
- MODULE CASE : HIGH TEMPERATURE THERMOPLASTIC, UL 94V-0, BLACK,HSF
- RJ CONTACTS :PHOSPHOR BRONZE , C5210R-H
- PLATING :SELECT GOLD ON CONTACT AREA,  
100u" MIN TIN PLATING ON SOLDER TAILS, 30u" MIN NICKEL OVERALL
- SOLDER TAIL TERMINAL :BRASS,C2680R-EH
- PLATING :100u" MIN TIN , 30u" MIN NICKEL OVERALL
- SHIELD :STAINLESS,THICKNESS=0.2mm, NICKEL OVERALL

**2.RJ45 SPECIFICATIONS**

- INSULATION RESISTANCE :500 MOHMS MIN
- INSERTION FORCE WITH THE LATCH DEPRESSED :22N MAX
- REMOVAL FORCE WITH THE LATCH DEPRESSED :44N MAX
- DURABILITY :750 CYCLES

**3.OPERATING AND STORAGE TEMPERATURE**

- OPERATING TEMPERATURE:0°C TO +70°C
- STORACE TEMPERATURE :-40°C TO +85°C

**4.TEMPERATURE CONDITION OF WAVE SOLDERING:**

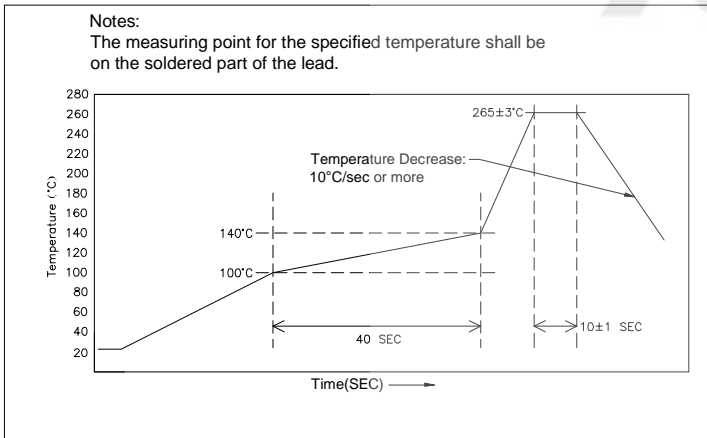

**ELECTRICAL CHARACTERISTICS :**

**1.INSERTION LOSS :**

- 1~100 MHZ -1.0dB MAX

**2.RETURN LOSS(LOAD 100Ω):**

- 1~40 MHZ -18dB MIN
- 40~100 MHZ -12+20LOG(f/80MHz)dB MIN

**3. COMMON MODE REJECTION**

- 1~100 MHZ -30dB MIN

**4.CROSS TALK**

- 1~100 MHZ -30dB MIN

**5.INDUCTANCE @ 100KHz , 0.1V , 8mA DC BIAS**

- (P1-P2) , (P3-P4) , (P7-P8) , (P9-P10):350 uH MIN

**6.HI-POT TEST**

- PCB SIDE TO CABLE SIDE:1500VAC
- 60S OR 2250VDC 60S

**7.TURNS RATION 100KHz**

- (P1-P2):(J1-J2)=1:1±3%
- (P3-P4):(J3-J6)=1:1±3%
- (P7-P8):(J4-J5)=1:1±3%
- (P9-P10):(J7-J8)=1:1±3%

JAADAXAXDDXH  
**A:RJ 45**  
**A:有线圈**  
**A:LED+屏蔽壳**  
**H:TRAY**  
**A:Gold Flash**  
**F:6u"**  
**H:15u"**  
**L:30u"**  
**M:50u"**  
**D:半金锡**

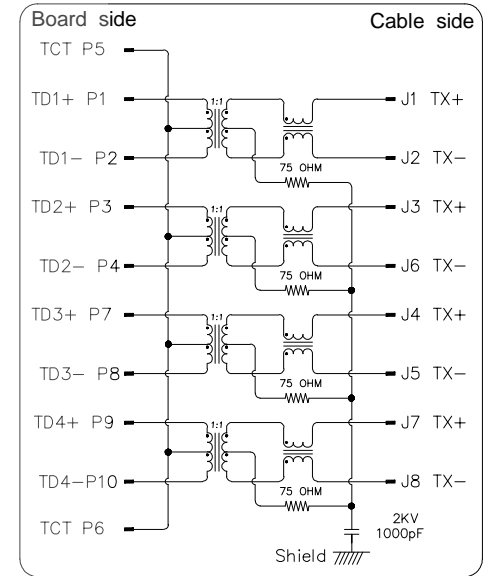

TOLERANCE TABLE	SCALE	1:1	DRAWN	江蒙	DATE	2024/05/28	DWG. NO. 600-0000-2452	TITLE RJ45 IMC,1000BASE-T, W/LED CUSTOMER DRAWING	REV.	1
	X. ± 0.30	X.° ± 3°	CHECK	李晨涛	DATE	2024/05/28			PARTS NO.(INTENDED USE) JAADAXAXDDXH	SHEET
	.X ± 0.25	.X° ± 2°	APPROVE	朱宁静	DATE	2024/05/28				
	.XX ± 0.20						SIZE	A4		