

版次	ECN 编码	描述		设计/日期
1	EL24050072	初版发行		江蒙_2024/05/28
		改前	改后	

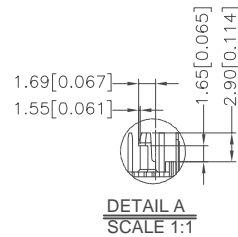

Emitting Color	λ_p (nm)	V_f @ $I_f=20\text{mA}$	I_r @ $V_r=5\text{V}$
Green	568	1.7V~2.6V	10uA max
Yellow	588	1.7V~2.6V	10uA max

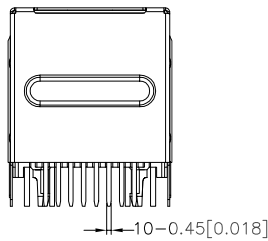
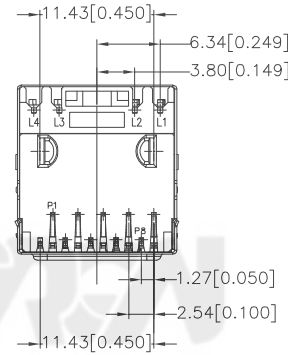
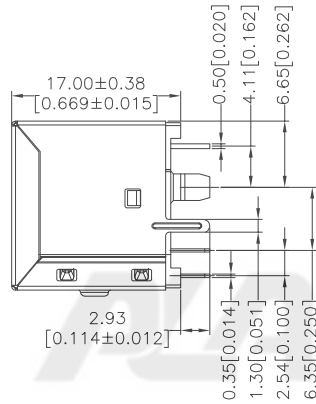
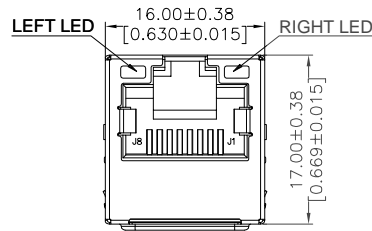
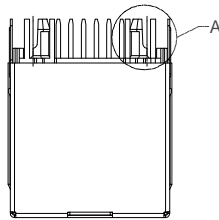
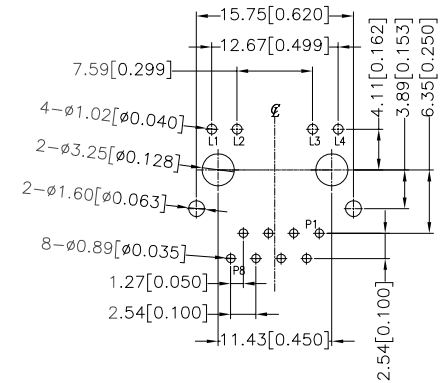

RECOMMENDED PCB LAYOUT



TOLERANCE TABLE	SCALE	2.5:1	DRAWN	江蒙	DATE	2024/05/28	DWG. NO.	TITLE	REV.
	X. ± 0.30	X.° ± 3°	UNIT	mm	CHECK	李晨涛		DATE	2024/05/28
	.X ± 0.25	.X° ± 2°	SIZE	A4	APPROVE	朱宁静	DATE	2024/05/28	SHEET
	.XX ± 0.20							1/2	
							PARTS NO.(INTENDED USE)	JAADAXFXDXH	
								RJ45 ICM, 100BASE-T, W/LED CUSTOMER DRAWING	

SPECIFICATIONS :

1.MATERIAL

- HQUSING: THERMOPLASTIC, PA6T BLACK, UL 94V-0
- SPACER: THERMOPLASTIC, PA6T BLACK, UL 94V-0
- RJ CONTACTS : PHOSPHOR BRONZE
- PLATING : GOLD ON CONTACT AREA (SEE PART NO),
100u" MIN TIN PLATING ON SOLDER TAILS, 30u" MIN NICKEL OVERALL
- SOLDER TAIL TERMINAL :BRASS
- PLATING : 100u" MIN TIN , 30u" MIN NICKEL OVERALL
- SHIELD : STAINLESS,THICKNESS=0.2mm,30u" MIN NICKEL OVERALL

2.RJ45 SPECIFICATIONS

- INSULATION RESISTANCE : 500 MOHMS MIN
- INSERTION FORCE WITH THE LATCH DEPRESSED :22N MAX
- REMOVAL FORCE WITH THE LATCH DEPRESSED :44N MAX
- DURABILITY :750 CYCLES

3.OPERATING AND STORAGE TEMPERATURE

- OPERATING TEMPERATURE:-40 °C TO +85°C
- STORAGE TEMPERATURE:-40 °C TO +85°C

4.TEMPERATURE CONDITION OF WAVE SOLDERING:

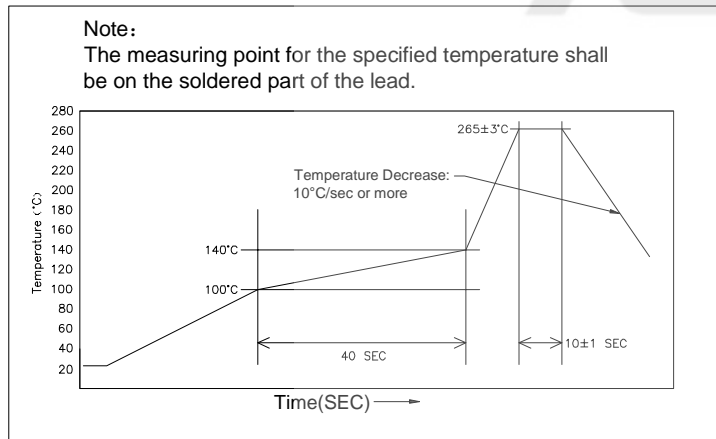

- JAADAXAFXDXH
- A:RJ 45
 - A:有线圈
 - A:LED+屏蔽壳
 - H:TRAY
 - A:Gold Flash
 - F:6u"
 - H:15u"
 - L:30u"
 - M:50u"
 - D:半金锡

ELECTRICAL CHARACTERISTICS:

- 1.INSERTION LOSS :
-1~100 MHz -1.1dB MAX
- 2.RETURN LOSS(LOAD 100Ω):
-1~30 MHz -16dB MIN
-30~60 MHz -14dB MIN
-60~80 MHz -10dB MIN
- 3.COMMON MODE REJECTION
-1~100 MHz -30dB MIN
- 4.CROSS TALK
-1~100 MHz -30dB MIN
- 5.INDUCTANCE @100KHz,0.1V,8mA DC BIAS
-(P1-P2),(P6-P7): 350 uH MIN
- 6.HI-POT TEST
-BOARD SIDE TO CABLE SIDE : 2250VDC 60S
- 7.TURNS RATION 100KHz
-(P1-P2):(J1-J2) = 1:1 ±%3
-(P6-P7):(J3-J6) = 1:1 ±%3

SCHEMATIC FOR RJ45:

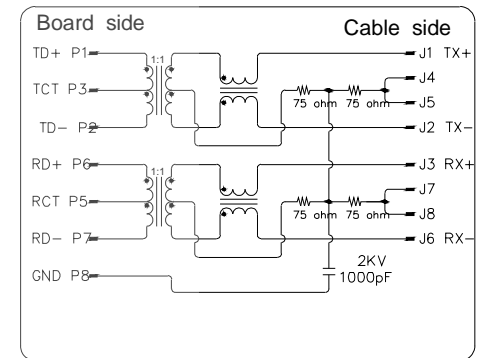

TOLERANCE TABLE	SCALE	1:1	DRAWN	江蒙	DATE	2024/05/28	DWG. NO.	TITLE	REV.
	X. ± 0.30	X.° ± 3°	CHECK	李晨涛	DATE	2024/05/28			
	.X ± 0.25	.X° ± 2°	APPROVE	朱宁静	DATE	2024/05/28	PARTS NO.(INTENDED USE)	RJ45 ICM, 100BASE-T, W/LED CUSTOMER DRAWING	SHEET 2/2
	.XX ± 0.20		SIZE	A4			JAADAXAFXDXH		