

Rev.	ECN Number	Description	Drawn
3	CH10090153	新增 PAD+REEL 包裝碼	楊加林_09/23'10
4	CH10120127	新增 無鹵編碼, 增加包裝視圖	IVANLUI_11/15'10

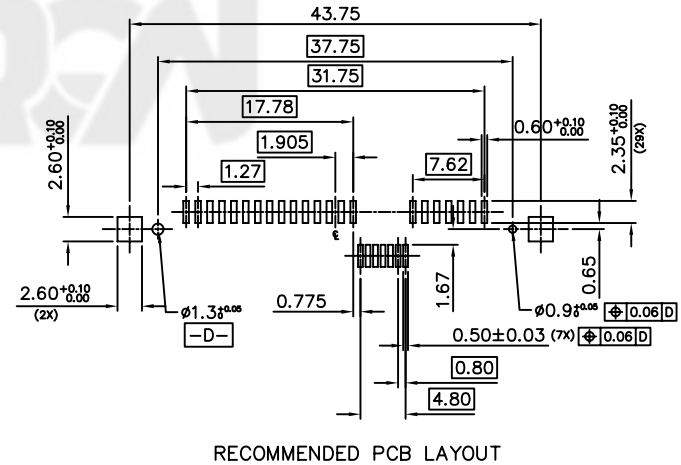
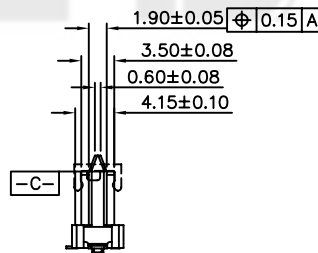
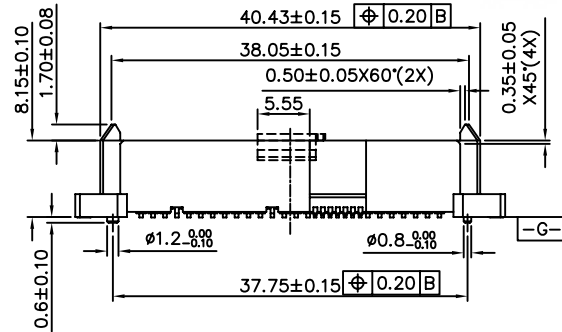
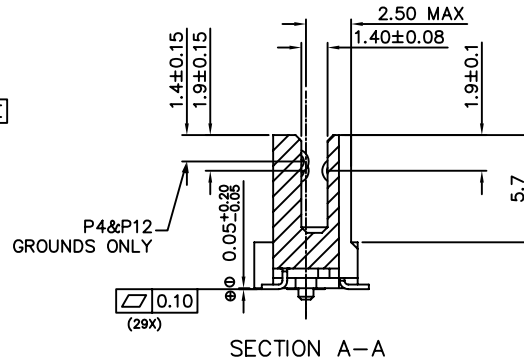
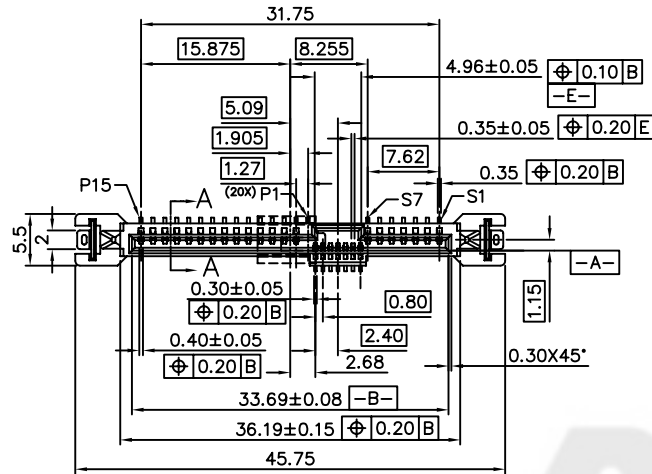

NOTE:

- 1) MATERIAL:
 - 1) HOUSING: HIGH TEMP TERMOPLASTIC UL 94V-0
 - 2) TERMINAL: COPPER ALLOY
 - 3) HOLD DOWN: COPPER ALLOY

2. PRODUCT NO. : SA 51 29 X-X-X

SATA CONN. RECEPTACLE SMT,V/T PIN NO. NULL: HALOGEN K: REEL H: HALOGEN FREE

PLATING

8: 30u" GOLD WITH LEAD FREE NULL: TUBE
 U: 30u" GOLD Sn/Pb K: REEL
 R: PAD+REEL

3. HARMFUL MATERIAL SHOULD BE COMPLIANT TO DOC"EI-0005" STANDARDS.



PLASTRON TECHNOLOGY (SHEN ZHEN) CO., LTD.

GENERAL TOLERANCE		SCALE	ORIGINAL DRAWN	DATE	DWG. NO.	TITLE	REV.
XX. ±	XXX. ±	1:1	BAYM	02/8'06	600-0000-088	CUSTOMER DRAWING	4
X. ± 0.30	.XXX ±	UNIT	Lane Sun	11/19'10			
.X ± 0.25	X.* ± 3°	MM			PARTS NO.(INTENDED USE)		SHEET
.XX ± 0.20	.X.* ± 2°	SIZE	Liss.xiang	11/19'10			SA5129*.* SERIES

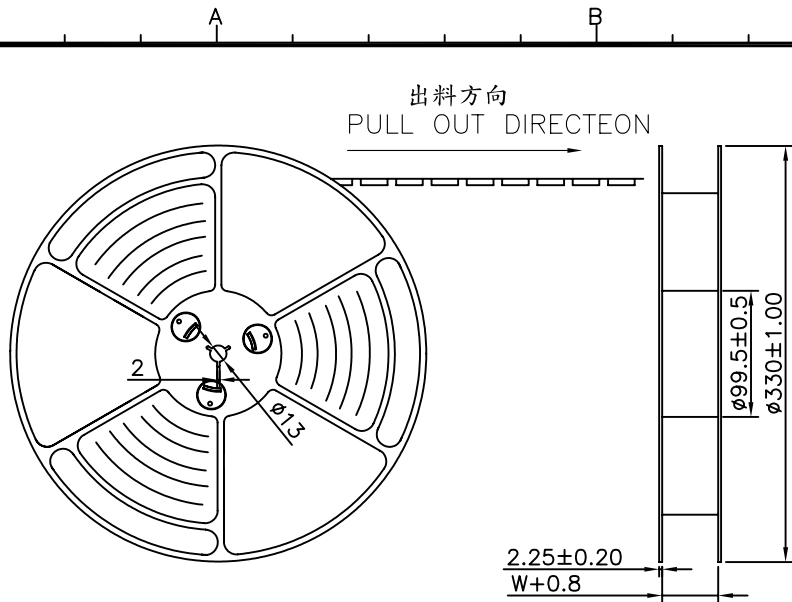

標籤黏貼處 (朝捲裝包材的小定位孔一側)
 Location of label sticking (label at small positioning hole of the carrier tape side).

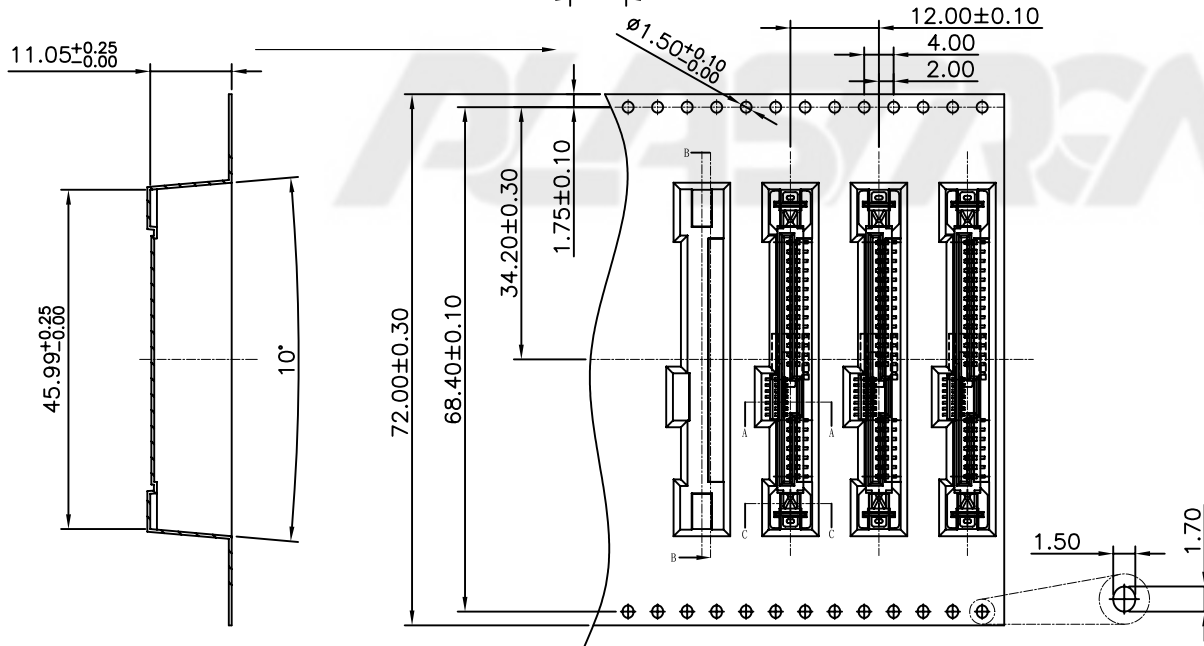
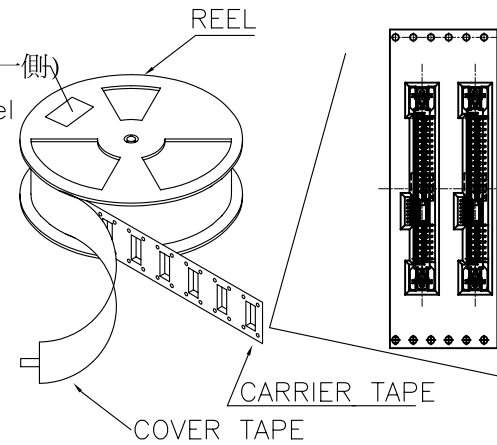

500	2	1000
PCS/REEL	REELS/CARTON	PCS/CARTON
包裝容量 (PACKING CAPACITY)		



GENERAL TOLERANCE	
XX. ± 0.50	XXX. ±
X. ± 0.30	.XXX ±
.X ± 0.25	X.* ± 3'
.XX ± 0.20	.X.* ± 2'

SCALE	1=1
UNIT	MM
SIZE	A4

ORIGINAL DRAWN
Ivan Lui

CHECK
Lane Sun

APPROVE
Liss Xiang

DATE 11/19'10

DATE 11/19'10

DATE 11/19'10

DWG. NO.
600-0000-088

PARTS NO.(INTENDED USE)
SA5129*-*-* SERIES

TITLE
CUSTOMER DRAWING

REV.
4

SHEET
2/3

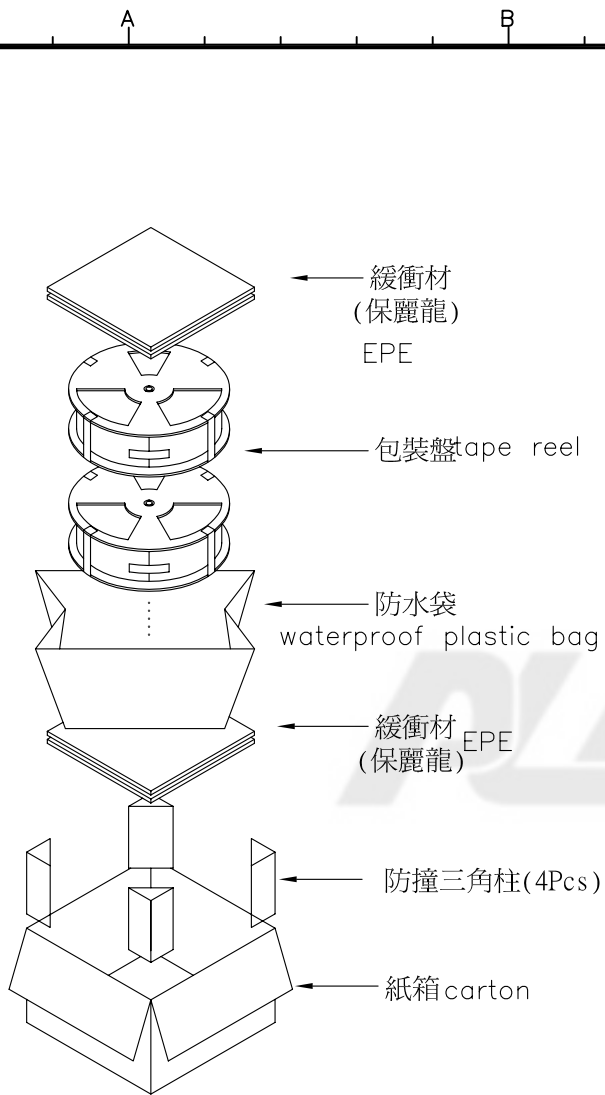

NOTES

1. 每捲包裝數量及每箱裝箱數量如上表格。
Packing q'ty of each reel & carton as up table shown.

2. 以上膠帶覆蓋下包裝帶經包裝機熱熔包裝
Use cover tape to cover and hot melt machine to seal up.

3. 每個紙箱放2個珍珠棉
Every carton use 2pcs EPE.

4. 將裝滿產品的卷盤放入紙箱并以膠帶封口
Put reels in the carton and use adhesive tape to seal up.

5. 帶子引導長度
LEAD TAPE LENGTH

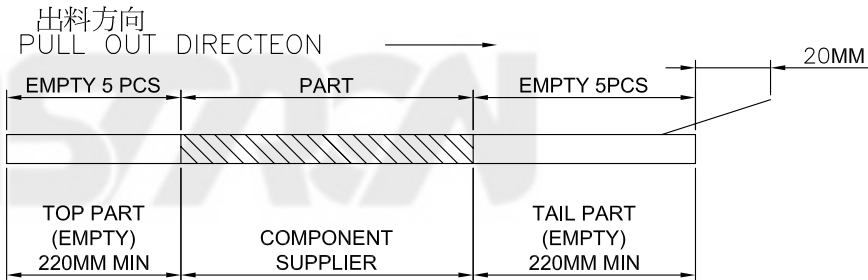

6. 上帶剝力力為：0.1~1.3 N(10.2gf~130gf)
PEELING OFF FORCE OF TOP TAPE:0.1~1.3N(10.2gf~130gf)

出貨'運輸過程中一定注意：

THIS REQUIREMENT SHOULD BE APPLIED AT SHIPMENT:

卷帶在運輸過程中不能散開

PEELING OFF SHOULD NOT BE ALLOWED DURING TRANSPORTATION

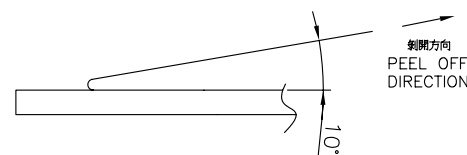

PLASTRON TECHNOLOGY (SHEN ZHEN) CO., LTD

GENERAL TOLERANCE	
XX. ± 0.50	XXX. ±
X. ± 0.30	.XXX ±
.X ± 0.25	X.* ± 3'
.XX ± 0.20	.X' ± 2'

SCALE	1=1
UNIT	MM
SIZE	A4

ORIGINAL DRAWN	Ivan Lui
CHECK	Lane Sun
APPROVE	Liss Xiang

DATE	11/19'10
DATE	11/19'10
DATE	11/19'10

DWG. NO.	600-0000-088
PARTS NO.(INTENDED USE)	SA5129*-*-* SERIES

TITLE	CUSTOMER DRAWING
-------	------------------

REV.	4
SHEET	3/3