

版次	ECN 编码	描述		设计/日期
1	EL24040025	初版发行		杜照鹏_2024/05/15
		改前	改后	

NOTES: (Unless otherwise specified)

1. MATERIAL:

1-1.HOUSING: PA10T+35%GF(VICNYL R635NH);UL 94V-0
COLOR:BLACK.

1-2.TERMINAL: PHOSPHOR BRONZE(C5210R-EH);T=0.30mm
TREATMENT:

1.GOLD FLASH ON CONTACT AREA,MATTE SN 50u" MIN
ON SOLDER TAIL,ALL OVER NI 30u" MIN.

1-3:SHELL: SUS(201);T=0.25mm,TREATMENT:50u" NI.

2.SPECIFICATIONS:

2-1.VOLTAGE RATING: 150VAC MAX.

2-2.CORRENT RATING: 1.5AMP MAX.

2-3.INSULATION RESISTANCE: 500mΩ MIN.AT 500V DC.

2-4.DIELECTRIC WITHSTANDING VOLTAGE:
500V AC 60HZ 1MINUTE.

2-5.DURABILITY: 5000 CYCLES.

2-6.OPERATING TEMPERATURE : -30°C TO +70°C.

2-7.FOR REFLOW SOLDERING LEAD-FREE RPROCESS.

JABCADBBXK

A:RJ45
B:PCB To Top
Height: 3.2mm
K:Reel
A:Gold Flash
L:30U"
B:Gold Plating

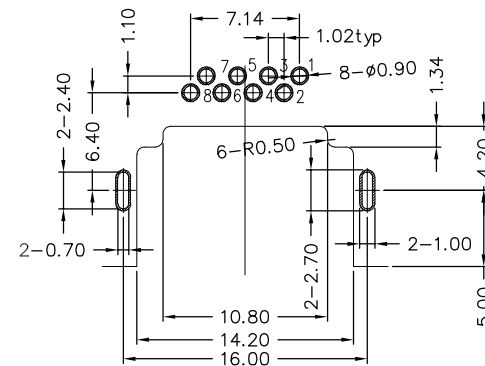

RECOMMENDED PCB LAYOUT

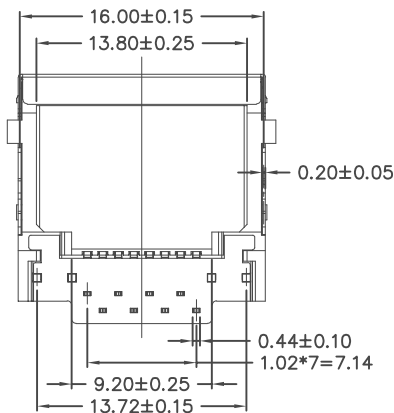
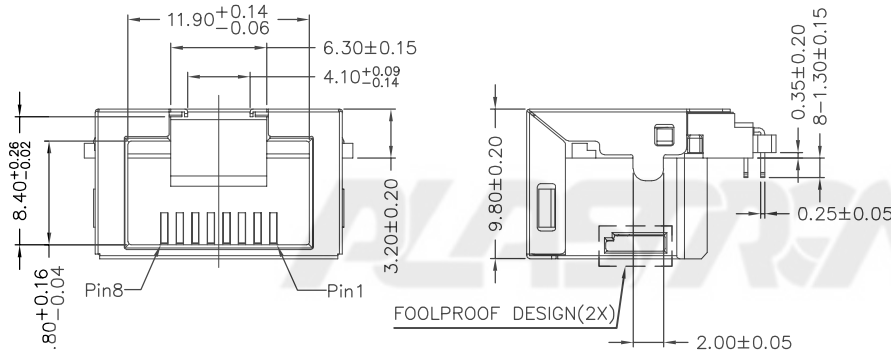
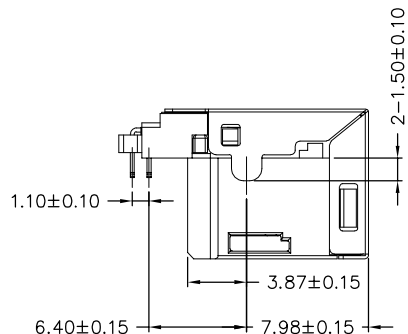
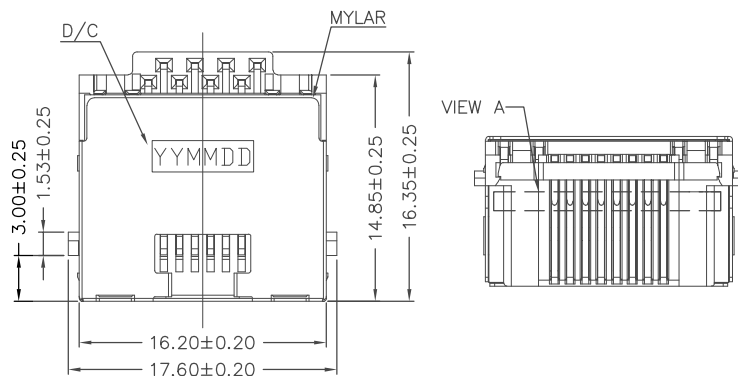
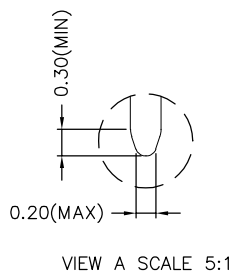

TOLERANCE TABLE	SCALE 2:1		DRAWN	杜照鹏	DATE	2024/05/15	DWG. NO.	600-0000-2434	TITLE	REV.
	X.± 0.30	X.° ± 3°								
	.X± 0.25	.X° ± 2°	SIZE	A4	APPROVE	朱宁静	DATE	2024/05/16	SHEET	1/1
	.XX ± 0.20							PARTS NO.(INTENDED USE)	JABCADBBXK	