

版次	ECN 编码	描述		设计/日期
1	EL24040027	初版发行		杜照鹏_2024/05/15
		改前	改后	

NOTES: (Unless otherwise specified)

1. MATERIAL:

1-1.HOUSING: PA9T,FILED;UL 94V-0 RATED OR OTHER HIGH PERFORMANCE RESINS

1-2.TERMINAL: PHOSPHOR BRONZE;T=0.30mm.

1-3.SHELL: SUS,T=0.20mm.

1-4:BOTTOM SHELL: SUS,T=0.20mm.

2.FINISH:

CONTACT: GOLD PLATING ON THE CONTACT AREA,AND MATTE TIN 100u" ON THE SOLDER TAIL AREA.

SHELL: COPPER ALLOY WHITE NICKEL.

3.PCB TOLERANCES: DIMENSION±0.05.

4.MECHANICAC CHARACTERISTICS:

4-1.MATING FORCE: 2.3kgf MAX.

4-2.UNMATING FORCES: 5.0kgf MIN.

4-3.KEEP OUT FEATURE OF PLUG: 8.0kgf MIN.

4-4.OPERATING TEMPERATURE: -30℃ TO +85℃.

JABCADVBXK

RJ45

V:PCB to Top

Height:8.45mm

K:Reel

A:Gold Flash

L:30U"

B:Gold Plating

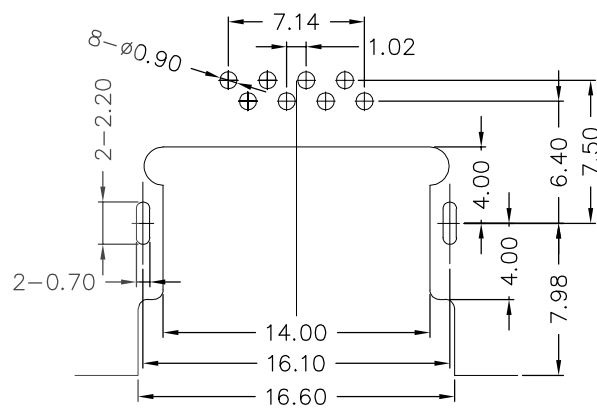

RECOMMENDED PCB LAYOUT



TOLERANCE TABLE	
X.± 0.30	X.° ± 3°
.X± 0.25	.X° ± 2°
.XX ± 0.20	

SCALE	2.5:1	DRAWN	杜照鹏	DATE	2024/05/15
UNIT	mm	CHECK	李晨涛	DATE	2024/05/15
SIZE	A4	APPROVE	朱宁静	DATE	2024/05/15

DWG. NO.	600-0000-2436
PARTS NO.(INTENDED USE)	JABCADVBXK

TITLE	RJ45 R/A.DIP.H8.45 CUSTOMER DRAWING
-------	--

REV.	1
SHEET	1/3

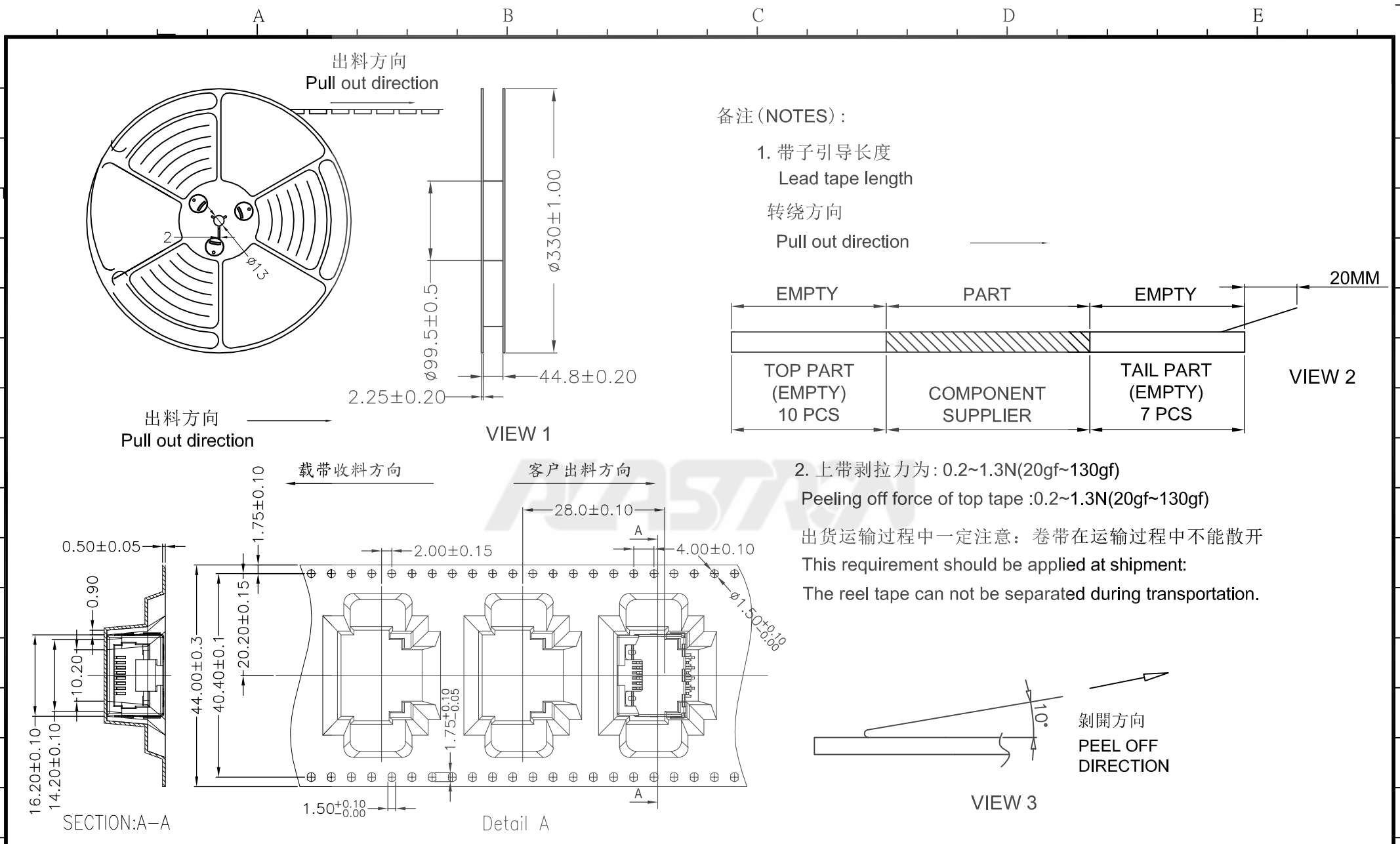

备注 (NOTES):

- 1. 带子引导长度  
Lead tape length
- 转绕方向  
Pull out direction

- 2. 上带剥拉力为: 0.2~1.3N(20gf~130gf)  
Peeling off force of top tape :0.2~1.3N(20gf~130gf)
- 出货运输过程中一定要注意: 卷带在运输过程中不能散开  
This requirement should be applied at shipment:  
The reel tape can not be separated during transportation.



	TOLERANCE TABLE		SCALE 1:1	DRAWN 杜照鹏	DATE 2024/05/15	DWG. NO. 600-0000-XXXX	TITLE	REV. 1
	X.± 0.30	X.° ± 3°	UNIT mm	CHECK 李晨涛	DATE 2024/05/15		PARTS NO.(INTENDED USE) JABCADVBXK	RJ45 R/A.DIP.H8.45 CUSTOMER DRAWING
	.X± 0.25	.X° ± 2°	SIZE A4	APPROVE 朱宁静	DATE 2024/05/15			
	.XX ± 0.20							

A

B

C

D

E

标签黏贴处(朝卷装包材的小定位孔一侧)  
 Location of label sticking (label at small positioning hole of the carrier tape side)

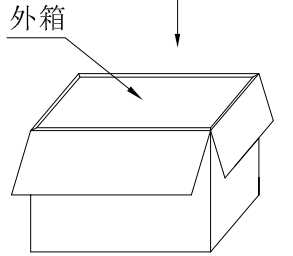
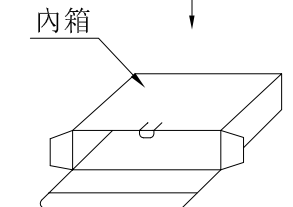
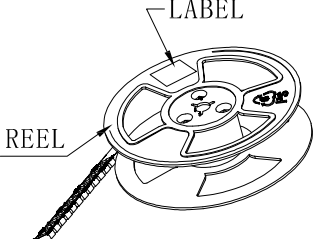

VIEW 4

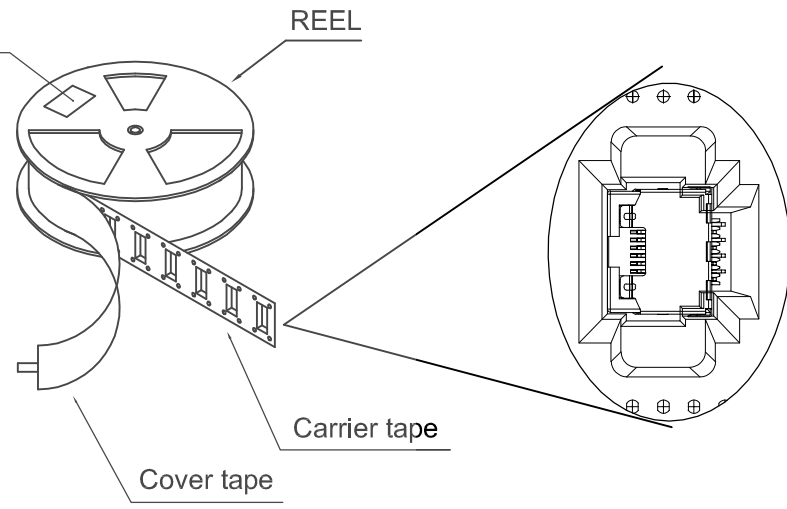
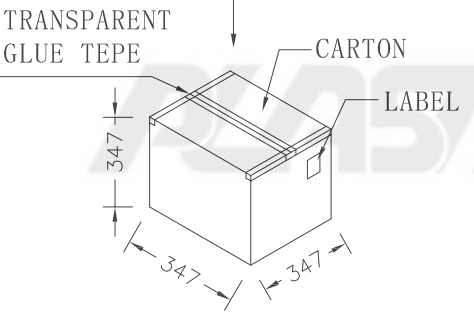
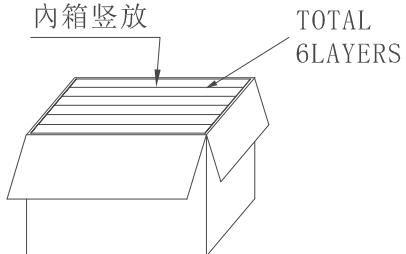

VIEW 5

备注 (NOTES):

- 1. 每卷包装数量及每箱装箱数量如下表格。  
Packing Q'ty of each reel & carton as below table shown.
- 2. 上胶带覆盖下包装带用自粘包装。  
Use cover tape to cover and seal up.
- 3. 将装满产品的卷盘放入纸箱并以胶带封口。  
Put reels in the carton and use adhesive tape to seal up.

产品料号 (Product No.)	包装数量 (Packing Quantity)		
	PCS/REEL	REELS/CARTON	PCS/CARTON
JABCADVBXK	200	6	1200



TOLERANCE TABLE	
X. ± 0.30	X.° ± 3°
.X ± 0.25	.X° ± 2°
.XX ± 0.20	

SCALE	1:1
UNIT	mm
SIZE	A4

DRAWN	杜照鹏
CHECK	李晨涛
APPROVE	朱宁静

DATE	2024/05/15
DATE	2024/05/15
DATE	2024/05/15

DWG. NO.	600-0000-XXXX
PARTS NO.(INTENDED USE)	JABCADVBXK

TITLE	RJ45 R/A.DIP.H8.45 CUSTOMER DRAWING
-------	--

REV.	1
SHEET	3/3

A

B

C

D

E