

A

B

C

D

E

版次	ECN 编码	描述		设计/日期
1	EL24050021	初版发行		江蒙_2024/05/17
		改前	改后	

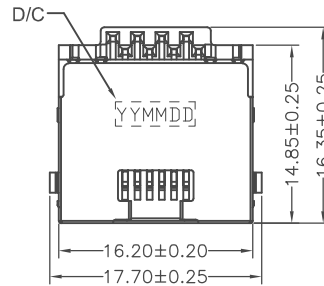
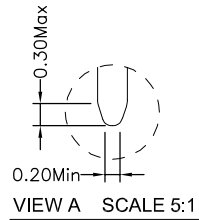

NOTES: (Unless otherwise specified)

1. MATERIAL:

1-1.HOUSING:PA10T+35%GF(VICNYL R635NH);UL 94V-0
COLOR:BLACK.

1-2.TERMINAL:PHOSPHOR BRONZE(C5210R-EH);T=0.3mm
TREATMENT:

1.GOLD FLASH ON CONTACT AREA,MATTE SN 50u" MIN
ON SOLDER TAIL,ALL OVER NI 30u" MIN.

1-3:SHELL:SUS(201);T=0.25mm,TREATMENT:50u" MIN.

2.SPECIFICATIONS:

2-1.VOLTAGE RATING:150VAC MAX.

2-2.CORRENT RATING:1.5AMP MAX.

2-3.INSULATION RESISTANCE:500mΩ MIN.AT 5000VDC.

2-4.DIELECTRIC WITHSTANDING VOLTAGE:

500V AC 60HZ 1MINUTE.

2-5.DURABILITY:5000 CYCLES.

2-6.OPERATING TEMPERATURE :-30°C TO +70°C.

2-7.FOR REFLOW SOLDERING LEAD-FREE RPROCESS.

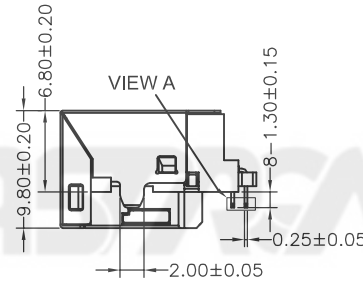
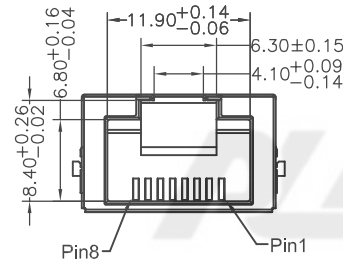
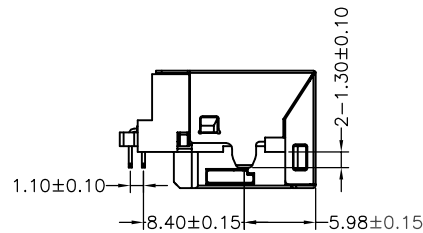

JABCADUBXK

A:RJ45

K:Reel

U: PCB to Top
Height: 6.8mm

A:Gold Flash
L:30u"

B:Gold Plating

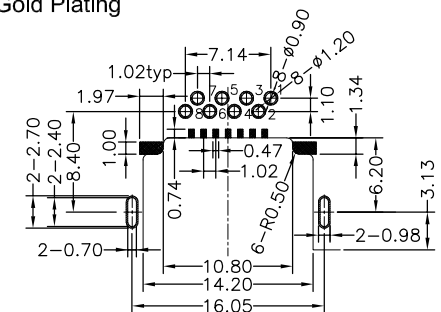
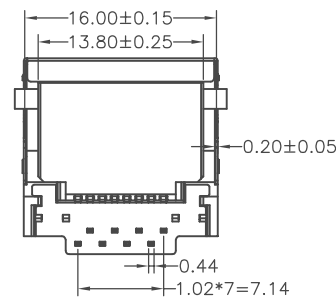
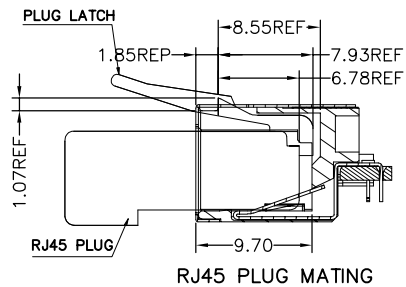

RECOMMENDED PCB LAYOUT

PLASTREN

TOLERANCE TABLE

X.± 0.30	X.° ± 3°
.X± 0.25	.X° ± 2°
.XX ± 0.20	

SCALE

2.5:1

DRAWN

江蒙

DATE

2024/05/17

DWG. NO.

600-0000-2433

TITLE

MINI RJ45 PHONE
JACK (板上6.80mm)
CUSTOMER DRAWING

REV.

1

CHECK

李晨涛

DATE

2024/05/17

PARTS NO.(INTENDED USE)

JABCADUBXK

SHEET

1/3

APPROVE

朱宁静

DATE

2024/05/17

A

B

C

D

E

A B C D E

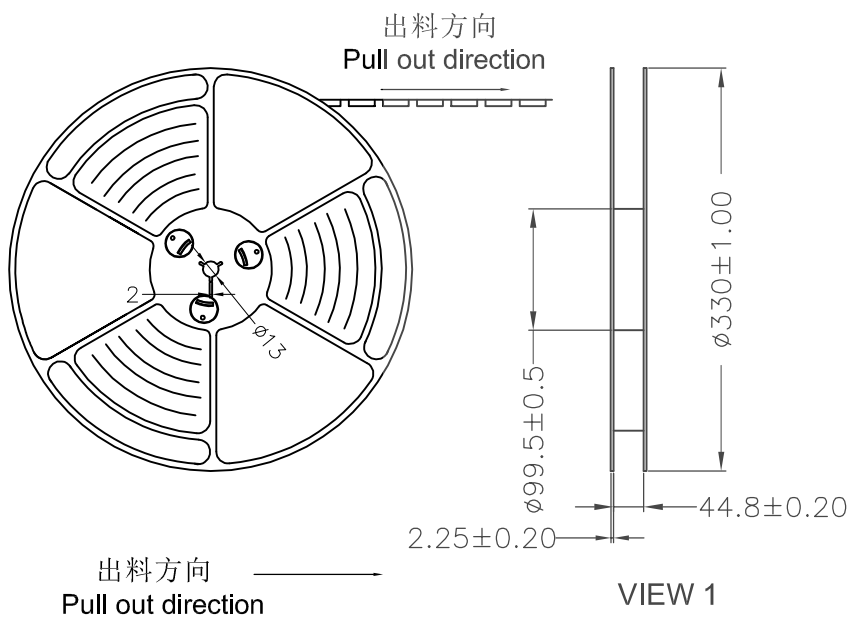

备注 (NOTES):

- 1. 带子引导长度
Lead tape length
- 转绕方向
Pull out direction

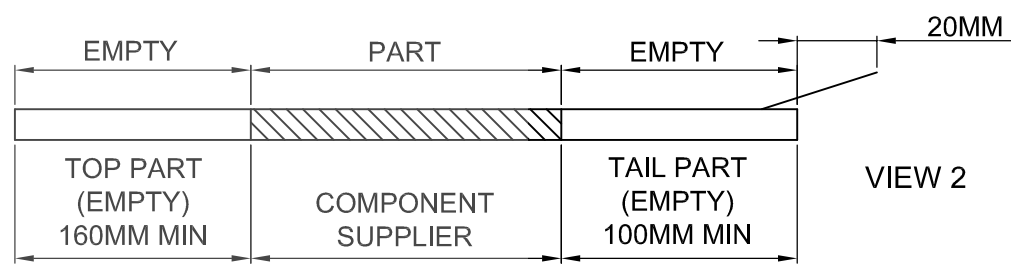

- 2. 上带剥拉力为: 0.2~1.3N(20gf~130gf)
Peeling off force of top tape :0.2~1.3N(20gf~130gf)

出货运输过程中一定注意: 卷带在运输过程中不能散开
This requirement should be applied at shipment:
The reel tape can not be separated during transportation.

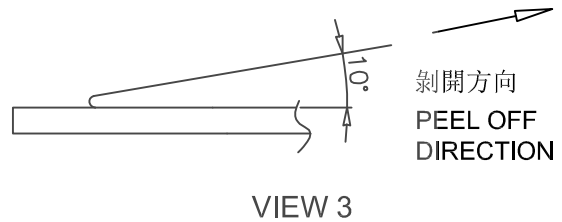
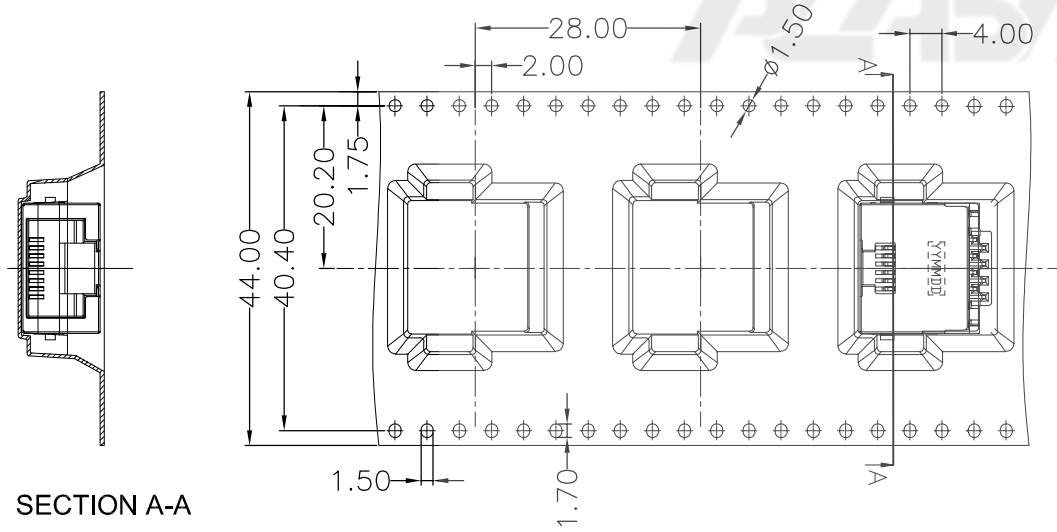

PLASTREN	TOLERANCE TABLE		SCALE	1:1	DRAWN	江蒙	DATE	2024/05/17	DWG. NO.	600-0000-2433	TITLE	REV.
	X. ± 0.30	X.° ± 3°	UNIT	mm	CHECK	李晨涛	DATE	2024/05/17				MINI RJ45 PHONE JACK (板上6.80mm)
	.X ± 0.25	.X° ± 2°	SIZE	A4	APPROVE	朱宁静	DATE	2024/05/17	PARTS NO.(INTENDED USE)	JBCADUBXK	CUSTOMER DRAWING	SHEET
	.XX ± 0.20											2/3

A B C D E

A

B

C

D

E

标签黏贴处(朝卷装包材的小定位孔一侧)
 Location of label sticking (label at small positioning hole of the carrier tape side)

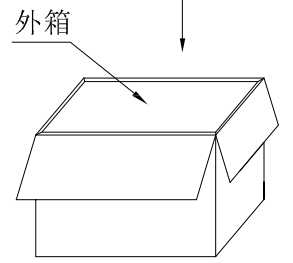
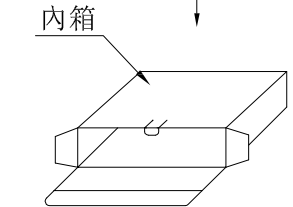
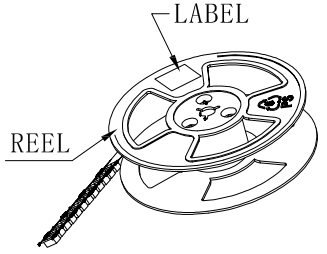

VIEW 4

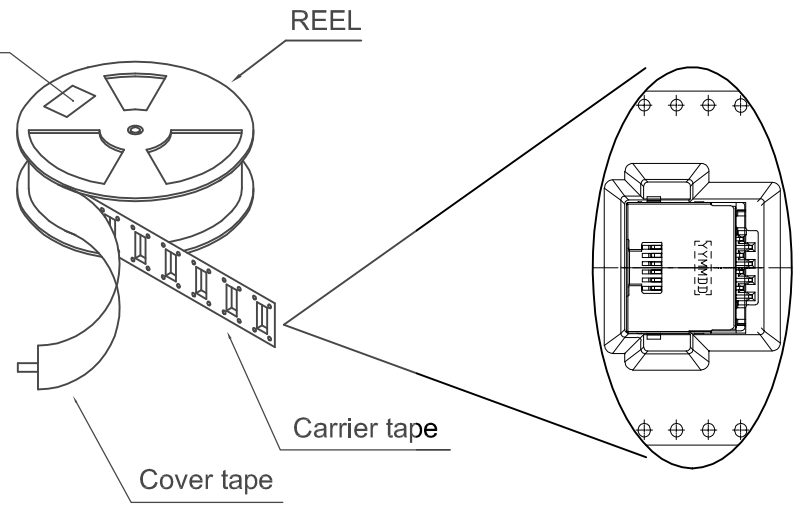
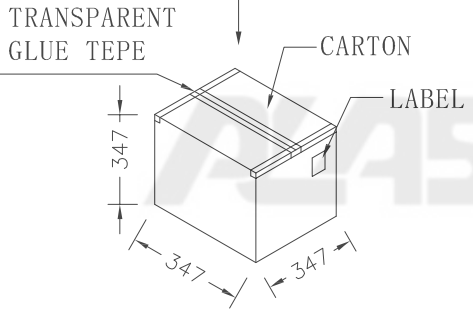
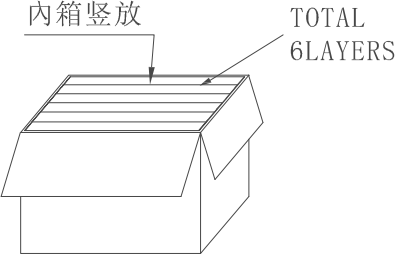

VIEW 5

备注 (NOTES):

1. 每卷包装数量及每箱装箱数量如下表格。
Packing Q'ty of each reel & carton as below table shown.
2. 上胶带覆盖下包装带用自粘包装。
Use cover tape to cover and seal up.
3. 将装满产品的卷盘放入纸箱并以胶带封口。
Put reels in the carton and use adhesive tape to seal up.

产品料号 (Product No.)	包装数量 (Packing Quantity)		
	PCS/REEL	REELS/CARTON	PCS/CARTON
JABCADUBXK	200	6	1200



TOLERANCE TABLE	
X. ± 0.30	X.° ± 3°
.X ± 0.25	.X° ± 2°
.XX ± 0.20	

SCALE	1:1
UNIT	mm
SIZE	A4

DRAWN	江蒙
CHECK	李晨涛
APPROVE	朱宁静

DATE	2024/05/17
DATE	2024/05/17
DATE	2024/05/17

DWG. NO.	600-0000-2433
PARTS NO.(INTENDED USE)	JABCADUBXK

TITLE	MINI RJ45 PHONE JACK (板上6.80mm) CUSTOMER DRAWING
-------	---

REV.	1
SHEET	3/3

A

B

C

D

E