

A B C D E

版次	ECN 编码	描述		设计/日期
1	EL24050018	初版发行		江蒙_2024/05/15
		改前	改后	

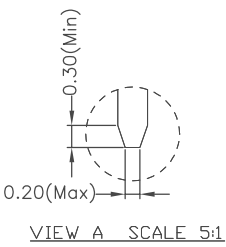
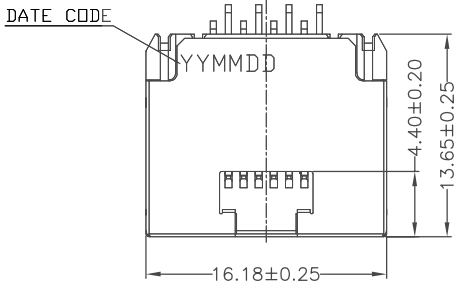

NOTES: (Unless otherwise specified)

1. MATERIAL:
 1-1.HOUSING:PA10T+35%GF(VICNYL R635NH);UL 94V-0
 COLOR:BLACK.
 1-2.TERMINAL:PHOSPHOR BRONZE(C5210R-EH);T=0.3mm
 TREATMENT:
 1.GOLD FLASH ON CONTACT AREA,MATTE SN 50u" MIN
 ON SOLDER TAIL,ALL OVER NI 30u" MIN.
 1-3.SHELL:SUS(201);T=0.25mm,TREATMENT:50u" MIN.

2.SPECIFICATIONS:
 2-1.VOLTAGE RATING:150VAC MAX.
 2-2.CORRENT RATING:1.5AMP MAX.
 2-3.INSULATION RESISTANCE:500mΩ MIN.AT 5000VDC.
 2-4.DIELECTRIC WITHSTANDING VOLTAGE:
 500V AC 60HZ 1MINUTE.
 2-5.DURABILITY:5000 CYCLES.
 2-6.OPERATING TEMPERATURE :-30°C TO +70°C.
 2-7.FOR REFLOW SOLDERING LEAD-FREE RPROCESS.

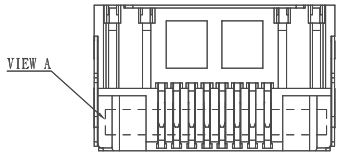
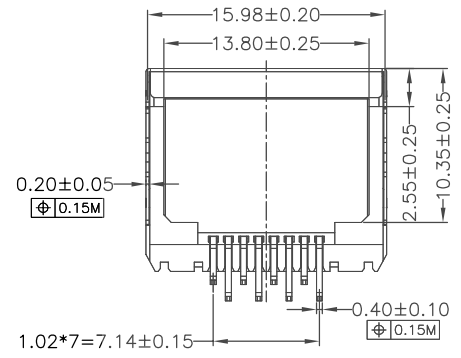
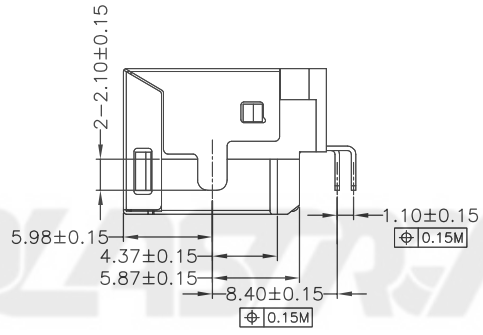
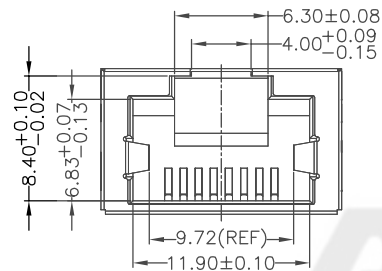
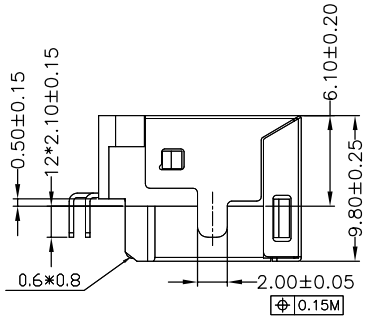

JABCAADMBAK

A:RJ45
 K:Reel
 A:8P8C
 A:Gold Flash
 B:Gold Plating

M: PCB to Top
 Height: 6.1mm

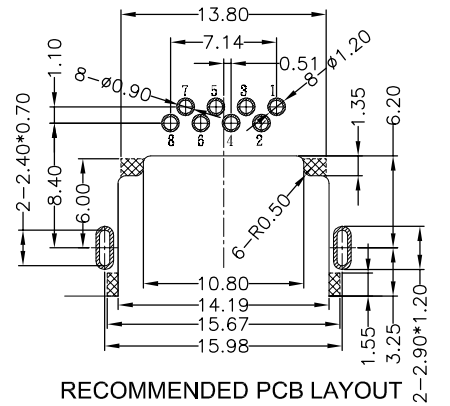

TOLERANCE TABLE	SCALE 2.5:1		DRAWN	江蒙	DATE	2024/05/15	DWG. NO.	TITLE	REV.
	X.± 0.30	X.°± 3°							
	.X± 0.25	.X.°± 2°	APPROVE	朱宁静	DATE	2024/05/15	PARTS NO.(INTENDED USE)	无LED	SHEET
	.XX± 0.20						JABCAADMBAK	CUSTOMER DRAWING	1/3

A B C D E

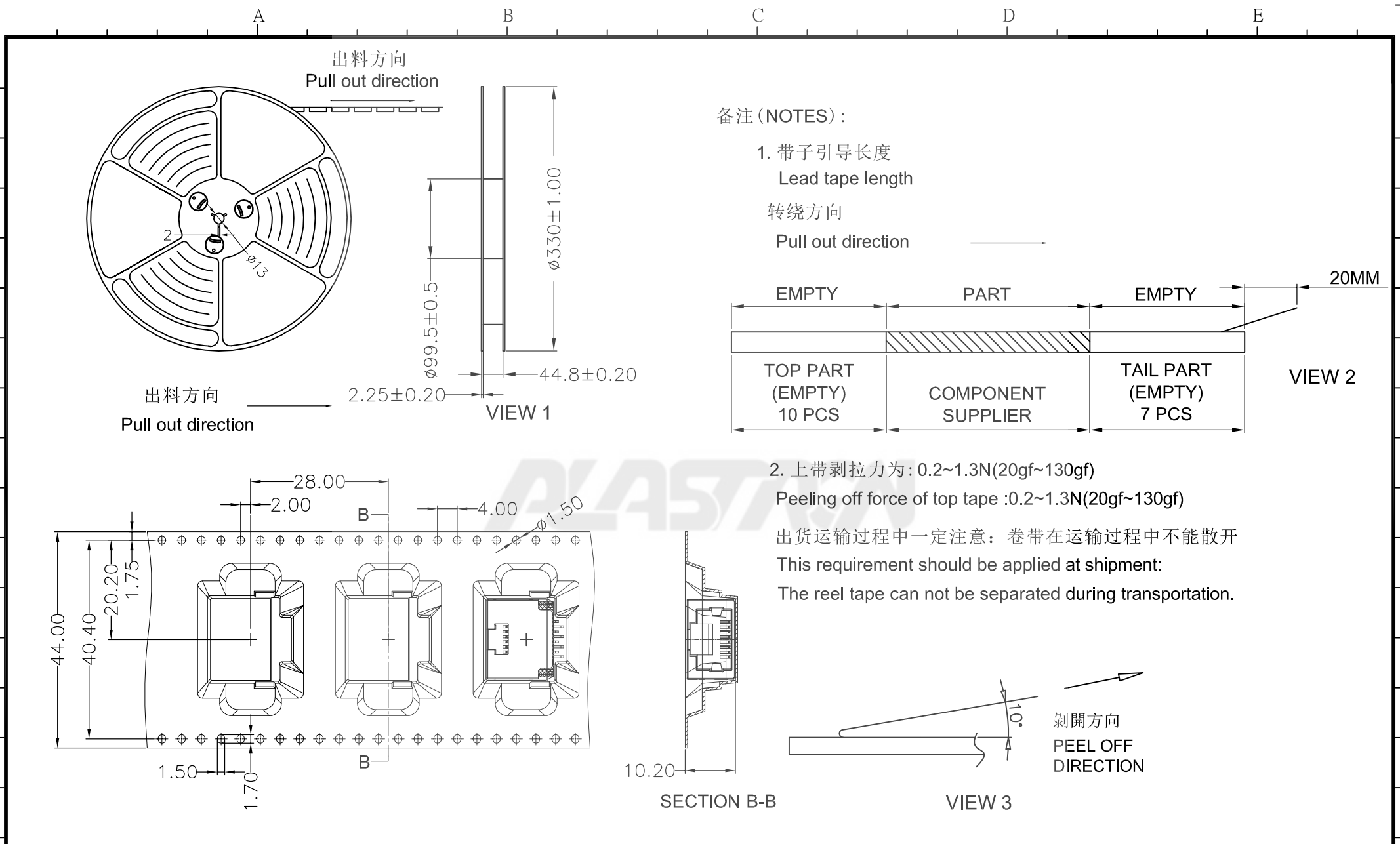

	TOLERANCE TABLE		SCALE 1:1	DRAWN 江蒙	DATE 2024/05/15	DWG. NO. 600-0000-2431	TITLE RJ45 8P8C(板上6.1mm) 无LED CUSTOMER DRAWING	REV. 1
	X. ± 0.30	X.° ± 3°	UNIT mm	CHECK 李晨涛	DATE 2024/05/15			PARTS NO.(INTENDED USE)
	.X ± 0.25	.X° ± 2°	SIZE A4	APPROVE	朱宁静	DATE 2024/05/15	JABCAADMBAK	SHEET 2/3
	.XX ± 0.20							

A B C D E

A

B

C

D

E

标签黏贴处(朝卷装包材的小定位孔一侧)
 Location of label sticking (label at small positioning hole of the carrier tape side)

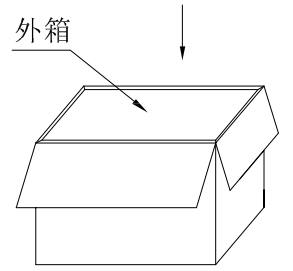
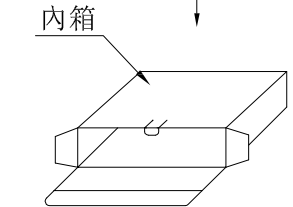
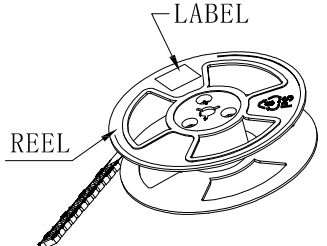

VIEW 4

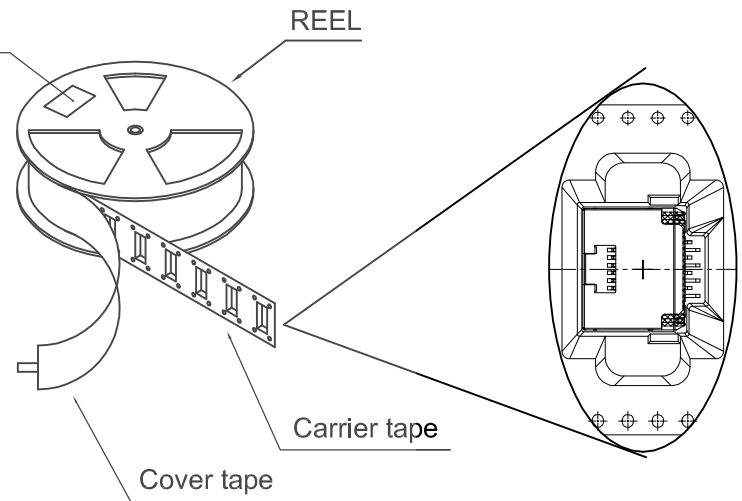
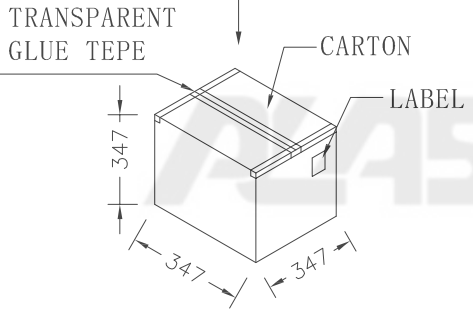
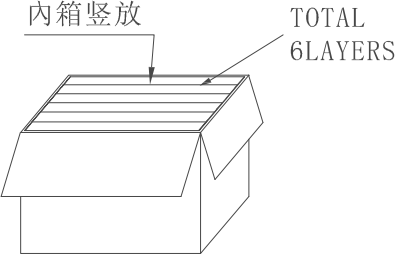

VIEW 5

备注 (NOTES):

- 每卷包装数量及每箱装箱数量如下表格。
Packing Q'ty of each reel & carton as below table shown.
- 上胶带覆盖下包装带用自粘包装。
Use cover tape to cover and seal up.
- 将装满产品的卷盘放入纸箱并以胶带封口。
Put reels in the carton and use adhesive tape to seal up.

产品料号 (Product No.)	包装数量 (Packing Quantity)		
	PCS/REEL	REELS/CARTON	PCS/CARTON
JABCAADMBAK	200	6	1200



TOLERANCE TABLE		SCALE 1:1	DRAWN 江蒙	DATE 2024/05/15	DWG. NO. 600-0000-2431	TITLE RJ45 8P8C(板上6.1mm) 无LED CUSTOMER DRAWING	REV. 1	
X. ± 0.30	X.° ± 3°	UNIT mm	CHECK 李晨涛	DATE 2024/05/15			PARTS NO.(INTENDED USE) JABCAADMBAK	SHEET 3/3
.X ± 0.25	.X° ± 2°	SIZE A4	APPROVE 朱宁静	DATE 2024/05/15				

A

B

C

D

E