

Pin No	Signal Name	Mating Sequence	Pin No	Signal Name	Mating Sequence
A1	GND	First	B12	GND	First
A2	TX1+	Second	B11	RX1+	Second
A3	TX1-	Second	B10	RX1-	Second
A4	Vbus	First	B9	Vbus	First
A5	CC1	Second	B8	SBU2	Second
A6	D+	Second	B7	D-	Second
A7	D-	Second	B6	D+	Second
A8	SBU1	Second	B5	CC2	Second
A9	Vbus	First	B4	Vbus	First
A10	RX2-	Second	B3	TX2-	Second
A11	RX2+	Second	B2	TX2+	Second
A12	GND	First	B1	GND	First
SHELL	GND		SHELL	GND	

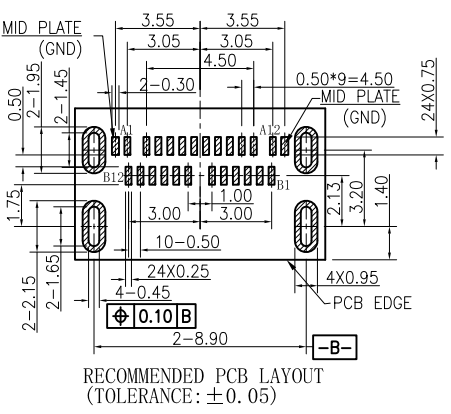
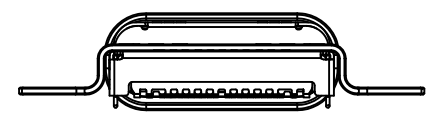
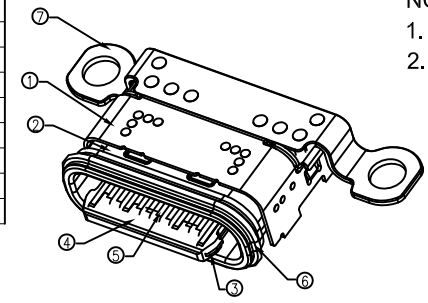
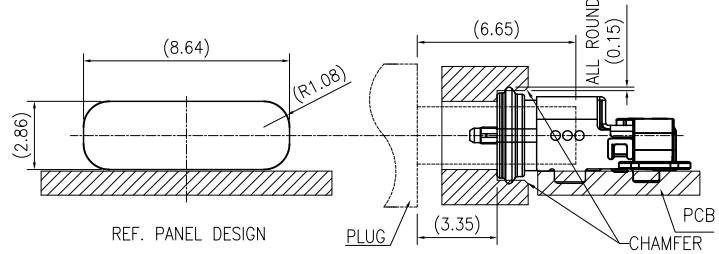
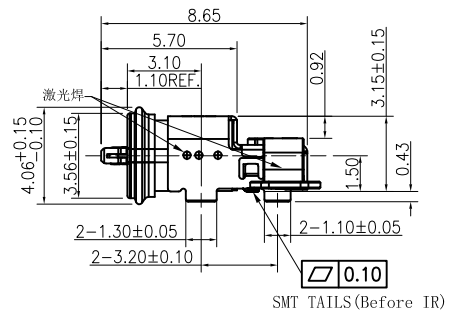

NOTES: (Unless otherwise specified)

- Dimension shall be interpreted per ANSI Y14.5M.
- Materials:  
Insulator material: High Temperature Thermoplastic, UL 94V-0; Color: Black.  
Contact material: Copper alloy. T=0.12mm  
Gold 30u" Plated On Contact Area, G/F On Solder Area  
50u" Ni Under Plated Overall  
Mid-Gnd: Stainless Steel,  
Mate Ground: Stainless Steel,  
Top Shell: Stainless Steel, Ni Plated 30u" Min Over all  
Shell: Stainless Steel, Ni Plated 30u" Min  
Gasket Ring: Silicone, Color: Blank
- Current Rating: 5A Max.
- Voltage Rating: 20V.
- Working Temperature: -40°C ~ +105°C.
- Water protection IPx8
- Harmful material should be compliant to doc. "EI-0005" standards.

REV	ECN NO.	DESCRIPTION	DESIGN/DATE
1	EH22070248	NEW DESIGN	XIAOMING_HE 2022/07/16
		BEFORE	AFTER



TOLERANCE TABLE	SCALE 2:1		DRAWN	何晓明	DATE	2022/07/16	DWG. NO.	600-0000-XXXX	TITLE	REV.
	X. ± 0.30	X.° ± 3°								
	.X ± 0.25	.X° ± 2°	APPROVE	DATE	MFEBN024KJ00		SHEET			
	.XX ± 0.20						1/3			

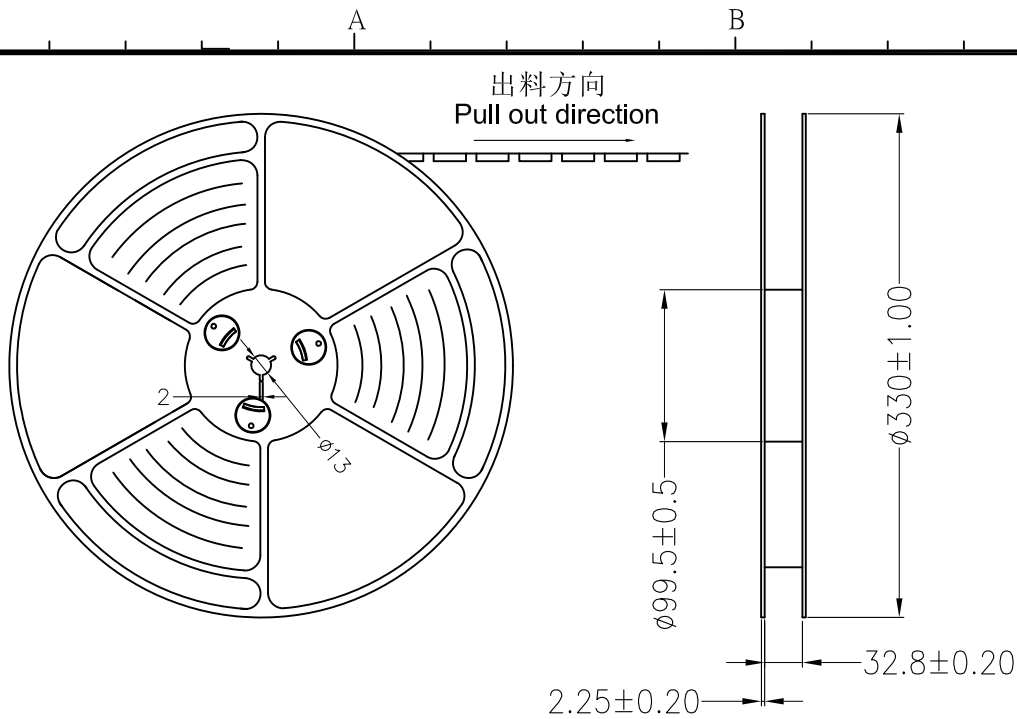

VIEW 1

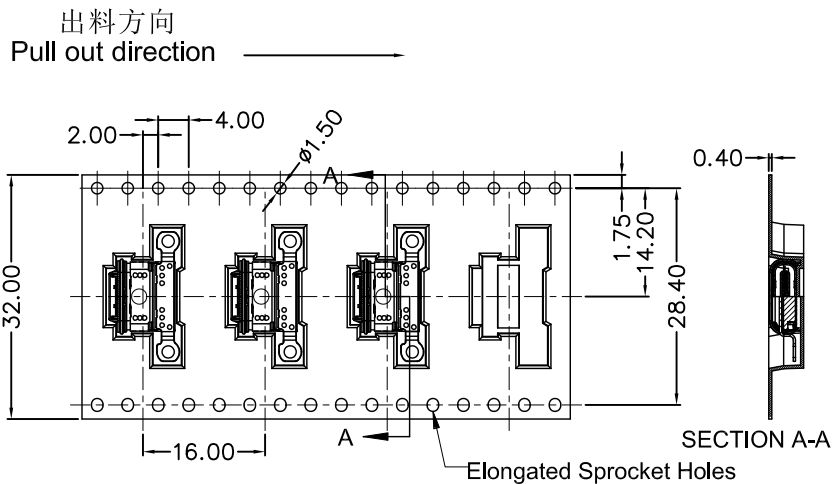

SECTION A-A

Elongated Sprocket Holes

备注 (NOTES):

- 带子引导长度  
Lead tape length

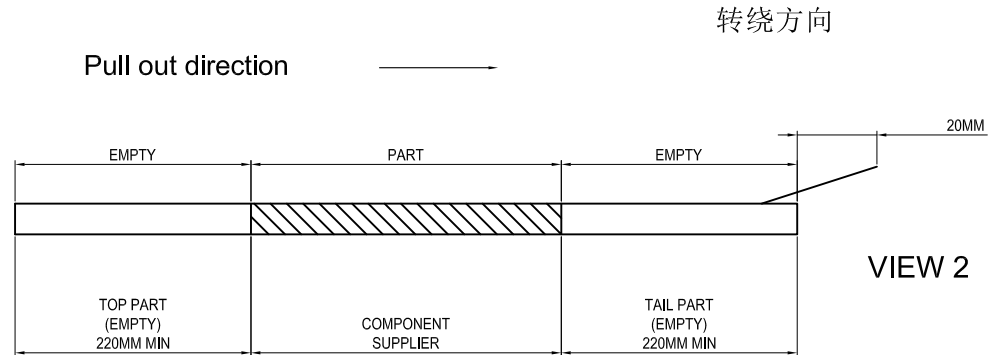

VIEW 2

- 上带剥拉力为: 0.2~1.3N(20gf~130gf)

Peeling off force of top tape :0.2~1.3N(20gf~130gf)

出货运输过程中一定注意: 卷带在运输过程中不能散开

This requirement should be applied at shipment:

The reel tape can not be separated during transportation.

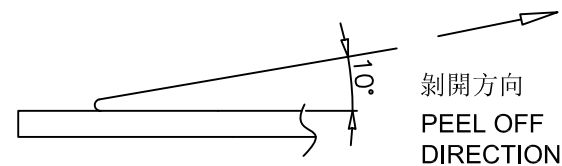

VIEW 3

PLASTREN

TOLERANCE TABLE		SCALE 1:1	DRAWN	何晓明	DATE	2022/07/16	DWG. NO.	TITLE	REV.
X. ± 0.30	X.° ± 3°	UNIT mm	CHECK		DATE		600-0000-XXXX	CUSTOMER DRAWING	1
.X ± 0.25	.X° ± 2°	SIZE A3	APPROVE		DATE		PARTS NO.(INTENDED USE)		SHEET
.XX ± 0.20							MFEBN024KJ00		2/3

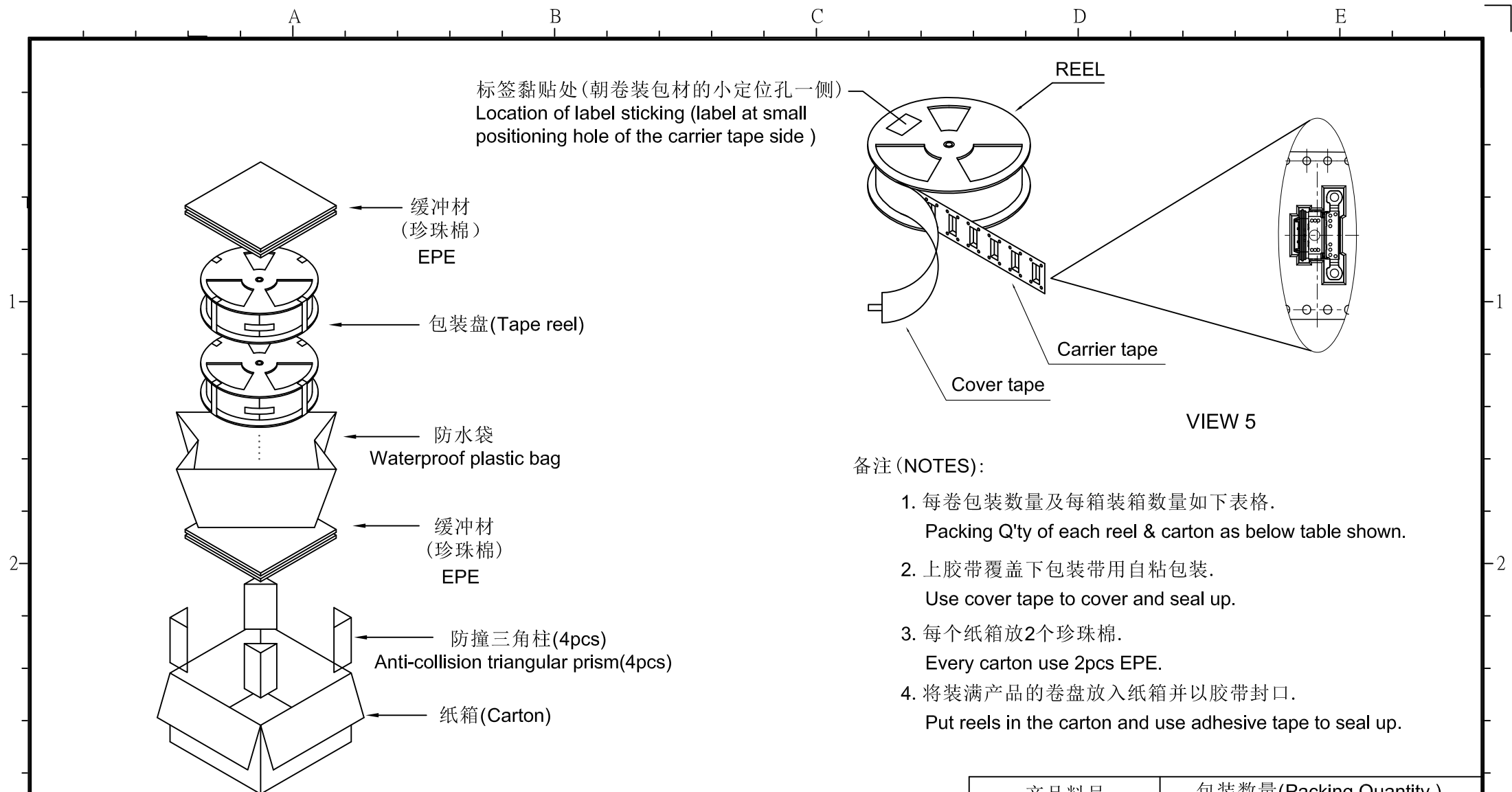

备注 (NOTES):

- 每卷包装数量及每箱装箱数量如下表格。  
Packing Q'ty of each reel & carton as below table shown.
- 上胶带覆盖下包装带用自粘包装。  
Use cover tape to cover and seal up.
- 每个纸箱放2个珍珠棉。  
Every carton use 2pcs EPE.
- 将装满产品的卷盘放入纸箱并以胶带封口。  
Put reels in the carton and use adhesive tape to seal up.

产品料号 (Product No.)	包装数量 (Packing Quantity)		
	PCS/REEL	REELS/CARTON	PCS/CARTON
MFEBN024KJ00	800	5	4000

	TOLERANCE TABLE		SCALE 1:1	DRAWN	何晓明	DATE	2022/07/16	DWG. NO.	600-0000-XXXX	TITLE	REV.
	X. ± 0.30	X.° ± 3°	UNIT	CHECK		DATE		PARTS NO. (INTENDED USE)			CUSTOMER DRAWING
	.X ± 0.25	.X° ± 2°	SIZE	APPROVE		DATE			MFEBN024KJ00	SHEET	
	.XX ± 0.20		A3								