

REV.	ECN NUMBER	DESCRIPTION	DRAWN_DATE
4	CH08090005	ADD NEW P/N	Ruby Deng_09/10'08
5	EH15010170	ADD NEW P/N(24,30)&Packaging Specification	Johnson.zhang_09/16'14
6	EH15120220	UPDATE DRAWING	ShiLu Yin-2015/12/24

NOTES: (UNLESS OTHERWISE SPECIFIED)

- DIMENSION SHALL BE INTERPRETED PER ANSI Y14.5M-1994
- MATERIAL:
HOUSING MATERIAL: High Temperature Thermoplastic, UL 94V-0.
CONTACT MATERIAL: BRASS, T=0.20mm
VACUUM COVER MATERIAL: STAINLESS STEEL, T=0.20mm
- Current rating: 1 A.
- Voltage rating: 100V AC/DC
- WORKING TEMPERATURE: -55° C To +85° C
- HARMFUL MATERIAL SHOULD BE COMPLIANT TO DOC. "EI-0005" STANDARDS.

7. PRODUCT NUMBER MATRIX:

HG10X-XXX-*		NULL: BLACK
STACKING HEIGHT		D: IVORY
1: H=8.35MM		PLATING CODE (lead free)
2: H=6.35MM		B: Plating Gold Flash
3: H=7.35MM		1: Plating Gold Flash, matte Sn 100μ" Min.
		2: Plating Au 3μ" Min. matte Sn 100μ" Min.
		3: Plating Au 5μ" Min. matte Sn 100μ" Min.
		4: Plating Au 10μ" Min. matte Sn 100μ" Min.
		5: Plating Au 15μ" Min. matte Sn 100μ" Min.
		6: Plating Au 20μ" Min. matte Sn 100μ" Min.
		7: Plating Au 50μ" Min. matte Sn 100μ" Min.
		8: Plating Au 30μ" Min. matte Sn 100μ" Min.

- NO. OF POS.
- 24=24POS.
 - 30=30POS.
 - 64=64POS.
 - 84=84POS.

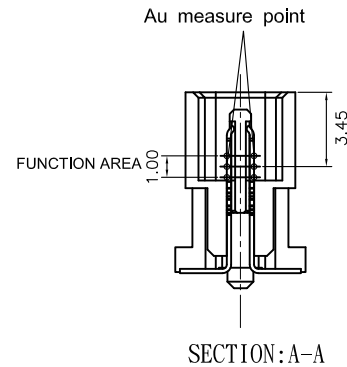
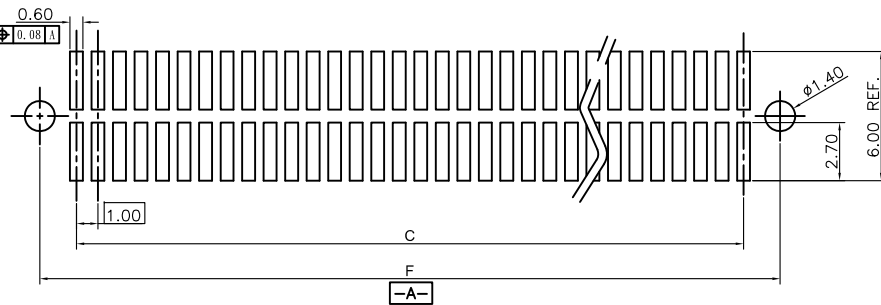
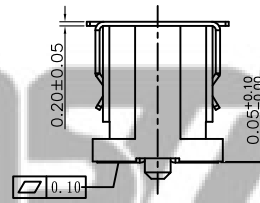
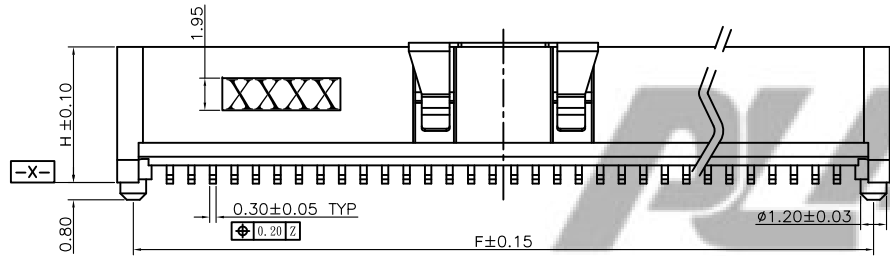
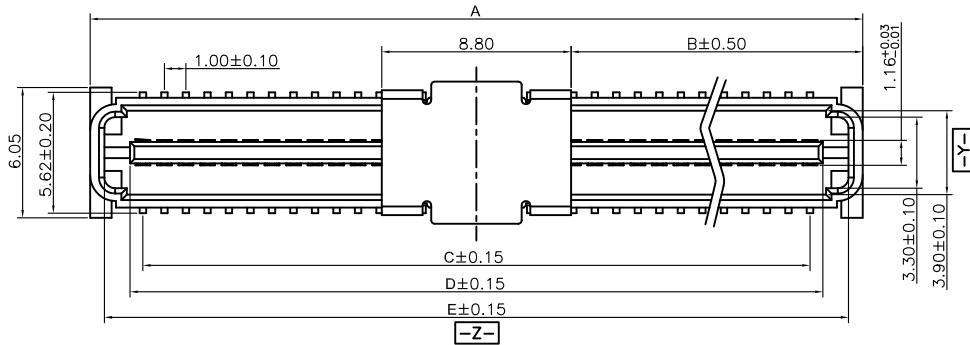

RECOMMENDED PCB LAYOUT
TOLERANCE±0.05

CKT	DIM A	DIM B	DIM C	DIM D	DIM E	DIM F
24	15.90	3.55	11.00	12.20	14.58	14.40
30	18.90	5.05	14.00	15.20	17.58	17.40
64	35.90	13.55	31.00	32.20	34.58	34.40
84	45.90	18.55	41.00	42.20	44.58	44.40

 PLASTREN TECHNOLOGY (SHEN ZHEN) CO., LTD.	GENERAL TOLERANCE		SCALE: 1:1	DRAWN: ShiLu Yin	DATE: 2015/12/24	DWG. NO: 600-0000-0313	TITLE: CUSTOMER_DRAWING 1.00PITCH_BT_B_PLUG	REV: 6
	X. ± 0.30	X.* ± 3°	UNIT: MM	CHECK: GuoHui Peng	DATE: 2015/12/24			PARTS. NO: HG10X-XXX-*_SERIES
	.X ± 0.20	.X* ± 2°	SIZE: A4	APPROVE: KuangHui Zou	DATE: 2015/12/24			
	.XX ± 0.10	.XX* ± 1°						
.XXX ± 0.05	.XXX* ±							

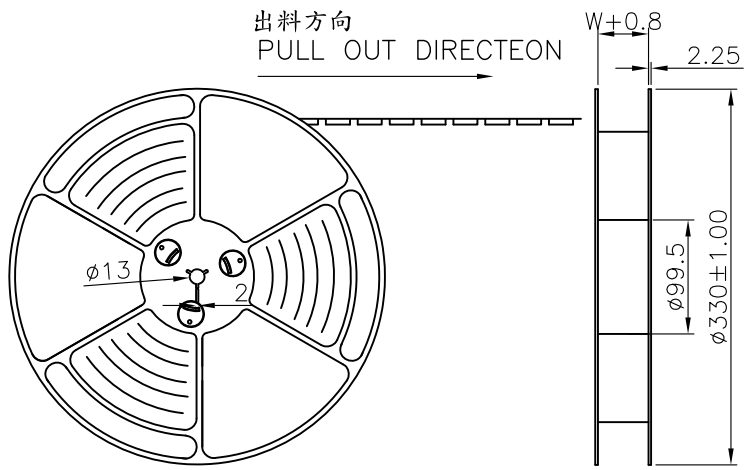

標籤黏貼處 (朝捲裝包材的小定位孔一側)
 Location of label sticking (label at small positioning hole of the carrier tape side).

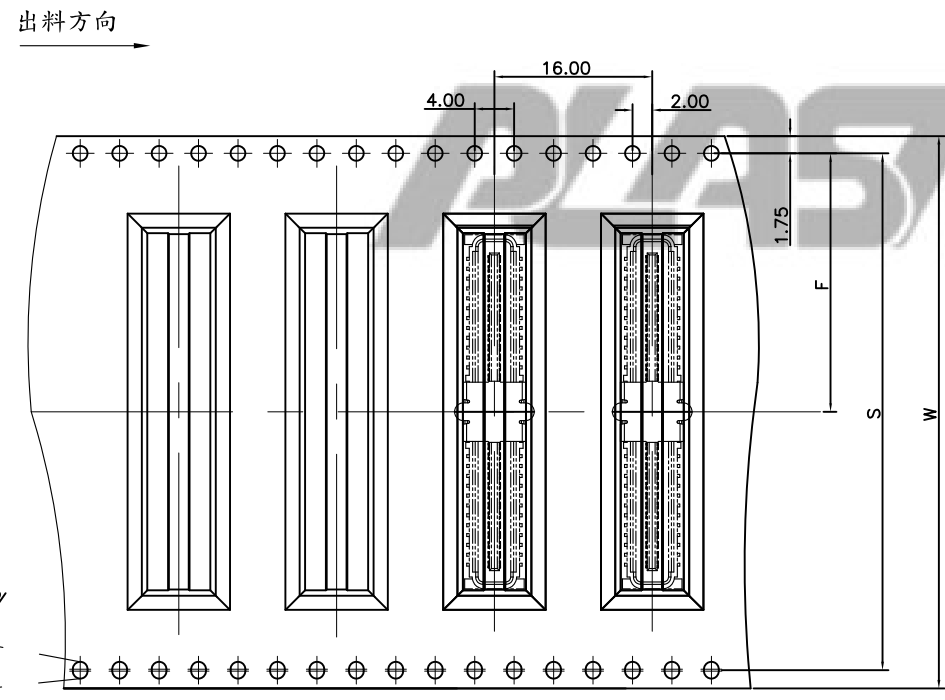
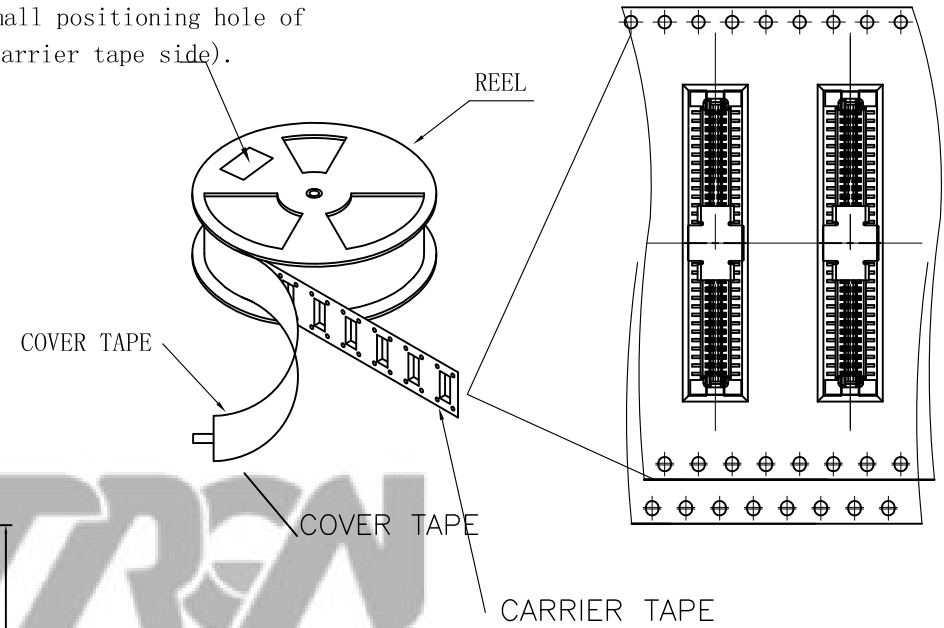

SERIES	P/N	W	S	F	PCS/REEL	REELS/CARTON	PCS/CARTON
HG103	84	72.0	68.4	34.2	600	2	1200
	64	56.0	52.4	26.2	600	3	1800
HG102	84	72.0	68.4	34.2	300	2	600
	64	56.0	52.4	26.2	500	3	900
HG101	84	72.0	68.4	34.2	400	2	800
	64	56.0	52.4	26.2	400	3	1200
	30	32.0	28.4	14.2	400	5	2000
	24	32.0	28.4	14.2	400	5	2000



GENERAL TOLERANCE	
X. ± 0.30	X.* ± 3°
.X ± 0.20	.X* ± 2°
.XX ± 0.10	.XX* ± 1°
.XXX ± 0.05	.XXX* ±

SCALE:	1:1
UNIT:	MM
SIZE:	A4

DRAWN:	ShiLu Yin
CHECK:	GuoHui Peng
APPROVE:	KuangHui Zou

DATE:	2015/12/24
DATE:	2015/12/24
DATE:	2015/12/24

DWG. NO:	600-0000-0313
PARTS. NO:	HG10X-XXX*_SERIES

TITLE:	CUSTOMER_DRAWING 1.00PITCH_BTBTB_PLUG
--------	--

REV:	6
SHEET:	2/3

A

B

C

D

E

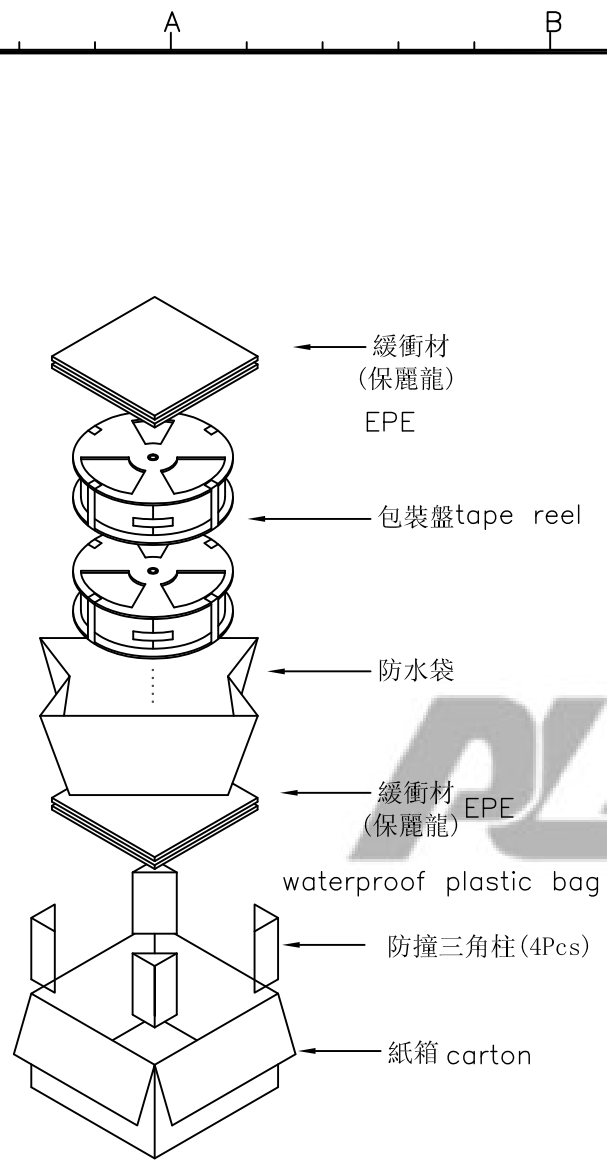

NOTE:

1. 每捲包裝數量及每箱裝箱數量如相上表格。
Packing q'ty of each reel & carton as up table shown
2. 以上膠帶覆蓋下包裝帶自粘包裝
Use cover tape with adhesive to cover self acting
3. 每個紙箱放2個珍珠棉
Every carton use 2pcs EPE.
4. 將裝滿產品的卷盤放入紙箱并以膠帶封口
Put reels in the carton and use adhesive tape to seal up.
5. 帶子引導長度
LEAD TAPE LENGTH

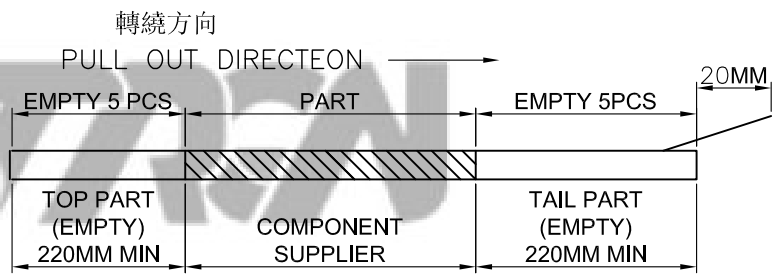

6. 上帶剝力力為: 0.1~1.3 N(10.2gf~130gf)
PEELING OFF FORCE OF TOP TAPE:0.1~1.3N(10.2gf~130gf)
出貨'運輸過程中一定注意:
THIS REQUIREMENT SHOULD BE APPLIED AT SHIPMENT:
卷帶在運輸過程中不能散開
PEELING OFF SHOULD NOT BE ALLOWED DURING TRANSPORTATION

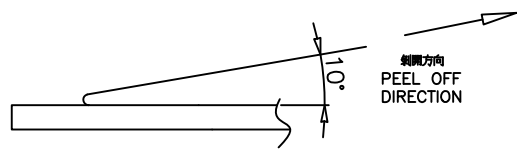

 PLASTRON TECHNOLOGY (SHEN ZHEN) CO., LTD.	GENERAL TOLERANCE		SCALE: 1:1	DRAWN: ShiLu Yin	DATE: 2015/12/24	DWG. NO: 600-0000-0313	TITLE: CUSTOMER_DRAWING	REV: 6
	X. ± 0.30	X.* ± 3°	UNIT: MM	CHECK: GuoHui Peng	DATE: 2015/12/24	PARTS. NO: HG10X-XXX-*_SERIES	1.00PITCH_BT B_PLUG	SHEET: 3/3
	.X ± 0.20	.X* ± 2°	SIZE: A4	APPROVE: KuangHui Zou	DATE: 2015/12/24			
	.XX ± 0.10	.XX* ± 1°						
	.XXX ± 0.05	.XXX* ±						