

40	78.00	80.00
39	76.00	78.00
38	74.00	76.00
37	72.00	74.00
36	70.00	72.00
35	68.00	70.00
34	66.00	68.00
33	64.00	66.00
32	62.00	64.00
31	60.00	62.00
30	58.00	60.00
29	56.00	58.00
28	54.00	56.00
27	52.00	54.00
26	50.00	52.00
25	48.00	50.00
24	46.00	48.00
23	44.00	46.00
22	42.00	44.00
21	40.00	42.00
20	38.00	40.00
19	36.00	38.00
18	34.00	36.00
17	32.00	34.00
16	30.00	32.00
15	28.00	30.00
14	26.00	28.00
13	24.00	26.00
12	22.00	24.00
11	20.00	22.00
10	18.00	20.00
09	16.00	18.00
08	14.00	16.00
07	12.00	14.00
06	10.00	12.00
05	8.00	10.00
04	6.00	8.00
03	4.00	6.00
02	2.00	4.00
Posts No. of	A	B
DIMENSIONS		

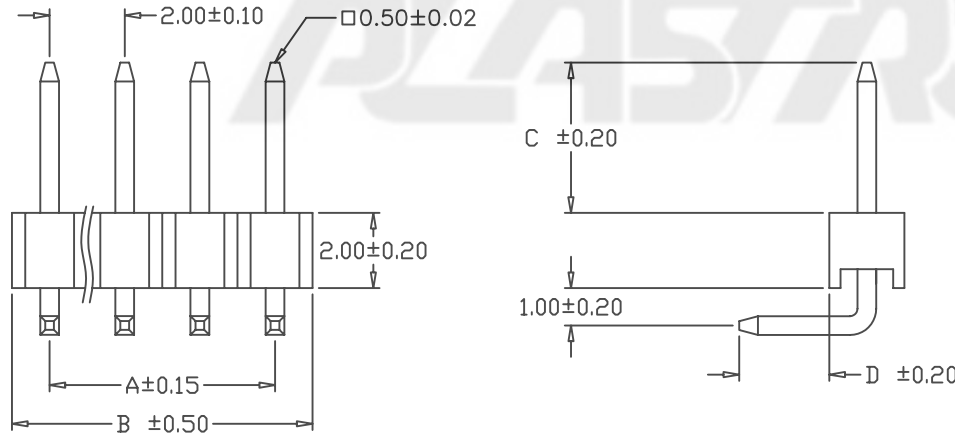
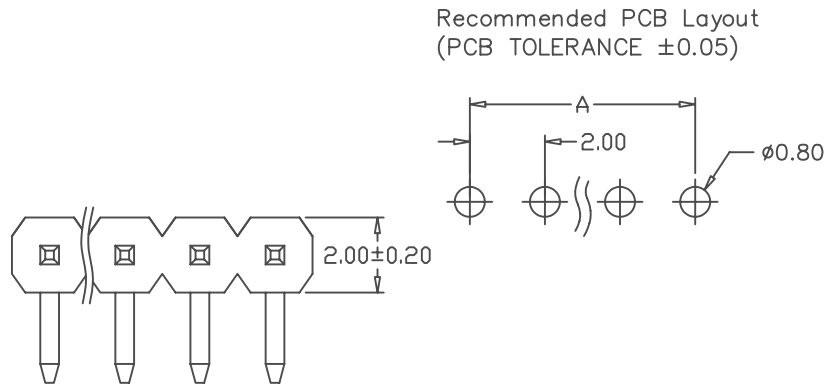

REV.	ECN NO.	Description	Drawn	APPD.
9	EW08050025	變更格式發行	Liangtang	林錫錦
10	EH08050169	新增料號和新增規格說明	Liangtang	Mabel.He 5/30'08
11	CH08120082	新增無鹵編碼	Tina Luo	Michael-H 12/15'08

NOTES: (UNLESS OTHERWISE SPECIFIED)

1. DIMENSION SHALL BE INTERPRETED PER ANSI Y14.5M-1994.
2. CONTACT RETENTION FORCE: 300g MIN, PER CONTACT.
3. DURABILITY: 50 CYCLES MIN.
4. RATING VOLTAGE: 30V A/DC.
5. CURRENT RATING: 1 AMPERE.
6. CONTACT RESISTANCE: 20 m ohms MAX, INITIAL.
7. DIELECTRIC WITHSTANDING VOLTAGE: 500V AC rms./MINUTE.
8. INSULATION RESISTANCE: 5000 Megohms MIN.
9. OPERATING TEMPERATURE:  $-40^{\circ}\sim+105^{\circ}\text{C}$ .
10. FINISH:

GOLD PLATED

◎ STANDARD: GOLD FLASH

◎ DUPLEX PLATING: GOLD PLATED ON CONTACT AREA,  
TIN PLATED ON SOLDER AREA

11. HARMFUL MATERIAL SHOULD BE COMPLIANT TO  
DOC. "EI-0005" STANDARDS.
12. PRODUCT NUMBER MATRIX:

XTY-XXR2-X-C/D-\*-\*

Pin type	Brass	L	B	P	NULL: WITH HALOGEN
	Brass(Bandolier)				H: HALOGEN FREE
	Phosphor Bronze				F: High temperature plastic
	◎Standard: L				NULL: PBT
Number of Contacts					Pin Length mm
Right Angle					Contact Plating

Definition	Code
◎ Tin plated	A
◎ Gold plated:	
flash B	5 μ* D 10 μ* E
15 μ* F	20 μ* G 30 μ* J
◎ Duplex plated	
flash K	5 μ* M 10 μ* N
15 μ* P	20 μ* Q 30 μ* U
◎Standard: B	
◎Prefix "v" means lead free plating	

	GENERAL TOLERANCE		SCALE 1=1	ORIGINAL DRAWN 陳美竹	DATE 03'/09/03	DWG. NO. 600-0000-0486	TITLE CUSTOMER DRAWING	REV. 11
	XX. $\pm 0.50$	XXX. $\pm$	UNIT MM	CHECK	DATE			SHEET
	X. $\pm 0.40$	.XXX $\pm$	SIZE A4	APPROVE	DATE 12/15'08	PARTS NO.(INTENDED USE) XTY-XXR2-X-C/D-*	2.00P HEADER	1/1
	.X $\pm 0.25$	X.* $\pm 4'$		Michael-H				
.XX $\pm 0.15$	.X* $\pm 3'$							