

No. of Contacts	DIMENSIONS	
	A	B
4	2.00	4.00
6	4.00	6.00
8	6.00	8.00
10	8.00	10.00
12	10.00	12.00
14	12.00	14.00
16	14.00	16.00
18	16.00	18.00
20	18.00	20.00
22	20.00	22.00
24	22.00	24.00
26	24.00	26.00
28	26.00	28.00
30	28.00	30.00
32	30.00	32.00
34	32.00	34.00
36	34.00	36.00
38	36.00	38.00
40	38.00	40.00
42	40.00	42.00
44	42.00	44.00
46	44.00	46.00
48	46.00	48.00
50	48.00	50.00
52	50.00	52.00
54	52.00	54.00
56	54.00	56.00
58	56.00	58.00
60	58.00	60.00
62	60.00	62.00
64	62.00	64.00
66	64.00	66.00
68	66.00	68.00
70	68.00	70.00
72	70.00	72.00
74	72.00	74.00
76	74.00	76.00
78	76.00	78.00
80	78.00	80.00

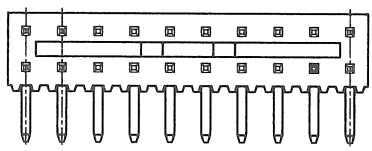

Less than 40pin

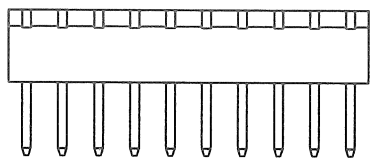
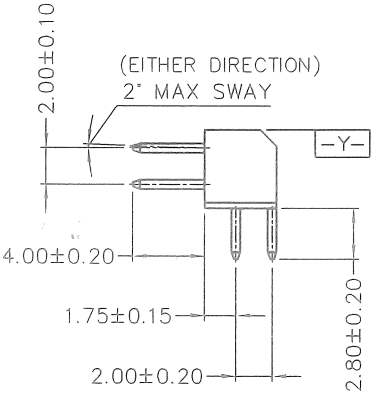
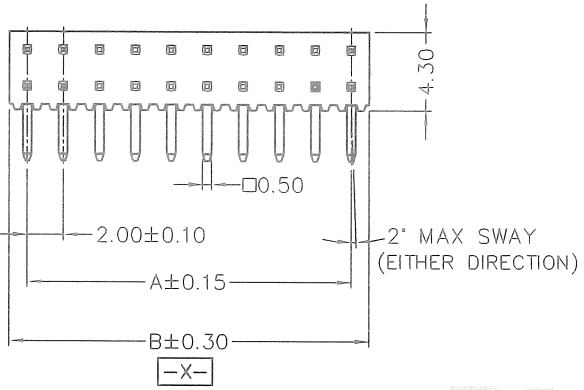
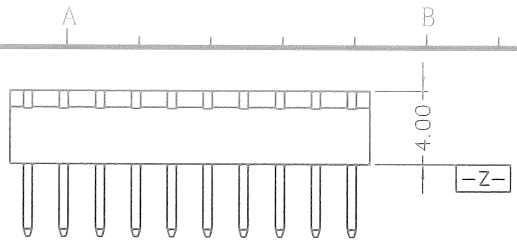

	Number of rib
44pin	4
66pin	1
40~48pin	3
50~58pin	4
60~68pin	5
70~80pin	6

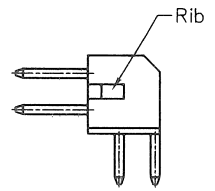

More than 40pin(included)

版次	ECN 编码	描述		设计/日期
1	EH19060189	初版发行		周雨博_2019/06/28
		改前	改后	

- NOTES: (Unless otherwise specified)
- Dimension shall be interpreted per ANSI Y14.5M.
 - Materials:
Insulator material: High Temperature Thermoplastic, UL 94V-0; Color: Black.
Contact material: Brass.
 - Current Rating: 1 A.
 - Voltage Rating: 30V AC/DC.
 - Working Temperature: -40°C ~ +105°C.
 - Harmful material should be compliant to doc. "EI-0005" standards.
 - Product number matrix:

B B H A B XXX G X 00

No. of contacts
Example 020:20pin

TUBE
Plating Code:

Definition	Code
● Tin plated	A
● Gold plated	
flash B 5 u" D 10 u" E	
15 u" F 20 u" G 30 u" J	
● Duplex plating	
flash K 5 u" M 10 u" N	
15 u" P 20 u" Q 30 u" U	
● Standard: B	
All Plating is lead free.	

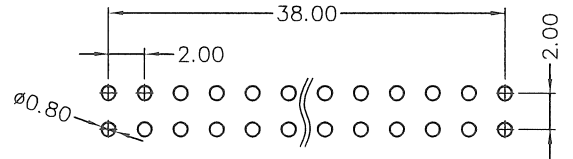

TOLERANCE TABLE		SCALE	2.5:1	DRAWN	周雨博	DATE	2019/06/28	DWG. NO.	600-0000-1970	TITLE	REV.
X. ± 0.30	X.° ± 3°	UNIT	mm	CHECK	周雨博	DATE	2019/06/28	PARTS NO.(INTENDED USE)	BBHABXXXGX00	CUSTOMER DRAWING	1
.X ± 0.25	.X° ± 2°	SIZE	A4	APPROVE	周雨博	DATE	2019/06/28				SHEET

- 一.
- 1) TUBE一端先以橡皮塞封住,将成品依序放入包装管。(包装数量见包装明细)
One end of the tube is sealed with soft stopper, then put the products into tube in seriate order.
(The quantity per tube see the detail of the packing)

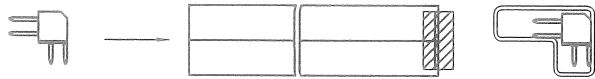

VIEW 1

- 二.
- 1) 将包装管两侧用软塞塞紧。
Plug the soft stopper on both sides of the packing tube.

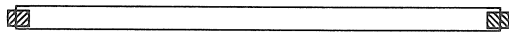

VIEW 2

- 三.
- 1) 包装管每10支用橡皮筋绑成一卷, 两端以保鲜膜缠绕, 将标签贴于同一方向。
Each the tubes are tied with a rubber band, Both ends wrapped with plastic wrap, Stick the label in the same direction.
 - 2) 包装管放入防水袋中后用胶带贴实封口。
Put the tubes into the waterproof bag and sealed with tape.
 - 3) 一只纸箱包装数量请见包装明细。
The quantity of the products per carton please follow the detail of the packing.

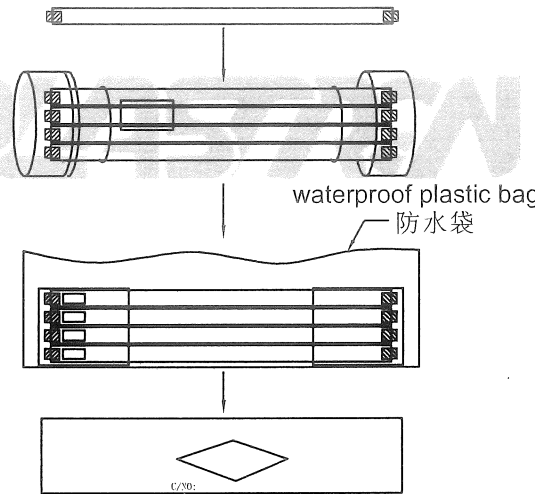

VIEW 3

- 四.
- 1) 将标签贴于指定的标签黏贴处。
Stick the label on the "Stick Label Area"

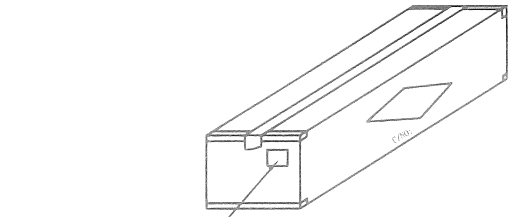

标签黏贴处
Stick Label Area

VIEW 4

备注(NOTES):

1. 若有未装满之零数箱, 必须以缓冲材塞满。
If the product's Q'ty is under MPQ, the carton must be filled with buffer material.
2. 装满成品后之外箱, 最大堆积箱数: 5箱。
The max. pile up number of packed carton is 5.
3. 具体包装数量请参照包装明细。
Please refer to the packing list for the actual packing details.
4. 如须贴Bar-code, 请依Bar-code作业办法执行。
If barcode is needed, please follow Barcode SOP.



TOLERANCE TABLE	
X. ± 0.30	X.° ± 3°
.X ± 0.25	.X° ± 2°
.XX ± 0.20	

SCALE	1:1
UNIT	mm
SIZE	A4

DRAWN	周雨博
CHECK	包国兴
APPROVE	朱宇辉

DATE	2019/06/28
DATE	2019/06/28
DATE	2019/06/28

DWG. NO.	600-0000-1970
PARTS NO.(INTENDED USE)	BBHABXXXGX00

TITLE	CUSTOMER DRAWING
-------	------------------

REV.	1
SHEET	2/3

产品料号 (Product No.)	包装数量 (Packing Quantity)			产品料号 (Product No.)	包装数量 (Packing Quantity)		
	PCS/TUBE	TUBES/CARTON	PCS/CARTON		PCS/TUBE	TUBES/CARTON	PCS/CARTON
BBHAB004GX00	153	240	36720	BBHAB044GX00	14	240	3360
BBHAB006GX00	102	240	24480	BBHAB046GX00	13	240	3120
BBHAB008GX00	77	240	18480	BBHAB048GX00	12	240	2880
BBHAB010GX00	61	240	14640	BBHAB050GX00	12	240	2880
BBHAB012GX00	51	240	12240	BBHAB052GX00	11	240	2640
BBHAB014GX00	44	240	10560	BBHAB054GX00	11	240	2640
BBHAB016GX00	38	240	9120	BBHAB056GX00	11	240	2640
BBHAB018GX00	34	240	8160	BBHAB058GX00	10	240	2400
BBHAB020GX00	30	240	7200	BBHAB060GX00	10	240	2400
BBHAB022GX00	28	240	6720	BBHAB062GX00	10	240	2400
BBHAB024GX00	25	240	6000	BBHAB064GX00	9	240	2160
BBHAB026GX00	23	240	5520	BBHAB066GX00	9	240	2160
BBHAB028GX00	22	240	5280	BBHAB068GX00	9	240	2160
BBHAB030GX00	20	240	4800	BBHAB070GX00	8	240	1920
BBHAB032GX00	19	240	4560	BBHAB072GX00	8	240	1920
BBHAB034GX00	18	240	4320	BBHAB074GX00	8	240	1920
BBHAB036GX00	17	240	4080	BBHAB076GX00	8	240	1920
BBHAB038GX00	16	240	3840	BBHAB078GX00	8	240	1920
BBHAB040GX00	15	240	3600	BBHAB080GX00	7	240	1682
BBHAB042GX00	14	240	3360				

	TOLERANCE TABLE		SCALE 1:1	DRAWN 周雨博	DATE 2019/06/28	DWG. NO. 600-0000-1970	TITLE CUSTOMER DRAWING	REV. 1
	X. ± 0.30	X.° ± 3°	UNIT mm	CHECK 周雨博	DATE 2019/06/28			PARTS NO.(INTENDED USE) BBHABXXXGX00
	.X ± 0.25	.X° ± 2°	SIZE A4	APPROVE 周雨博	DATE 2019/06/28			
	.XX ± 0.20		