

版次	ECN 编码	描述		设计/日期
		改前	改后	
6	EL23030113		修正关键尺寸标识与客户一致	李晨涛_2023/03/28
7	EL23090011	Plating Ni 50-160u"	Plating Ni 50-110u"	李晨涛_2023/09/07

NOTES: (Unless otherwise specified)

1. Dimension shall be interpreted per ANSI Y14.5M.

2. Materials:

Insulator material: High Temperature Thermoplastic, UL 94V-0; Color: Black.

Contact material: Copper alloy.

3. Current Rating: 3A per pin.

4. Voltage Rating: 250V AC/DC.

5. Working Temperature: -55°C ~ +125°C.

6. Contact retention force: 1000g Min per contact.

PAD retention force: 500g Min.

7. Harmful material should be compliant to doc.

"EI-0005" standards.

8. Product number matrix:

BAHEA008RA00

PAD+REEL

Plating Code:

Surface area: Plating matte Sn 120-240u"

The bottom layer: Plating Ni 50-110u"



TOLERANCE TABLE	
X. ± 0.30	X.° ± 3°
.X ± 0.25	.X° ± 2°
.XX ± 0.20	

SCALE	4:1
UNIT	mm
SIZE	A4

DRAWN	李晨涛
CHECK	朱文鹤
APPROVE	李晨涛

DATE	2023/09/07
DATE	2023/09/07
DATE	2023/09/07

DWG. NO.	600-0000-2162
PARTS NO.(INTENDED USE)	BAHEA008RA00

TITLE	CUSTOMER DRAWING
-------	------------------

REV.	7
SHEET	1/3

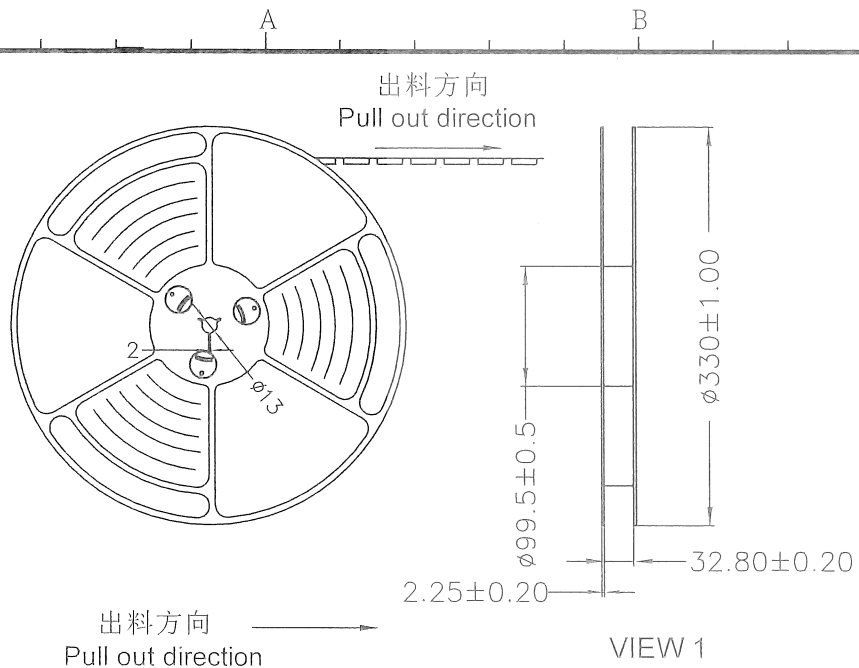

备注 (NOTES):

- 带子引导长度
Lead tape length
转绕方向
Pull out direction

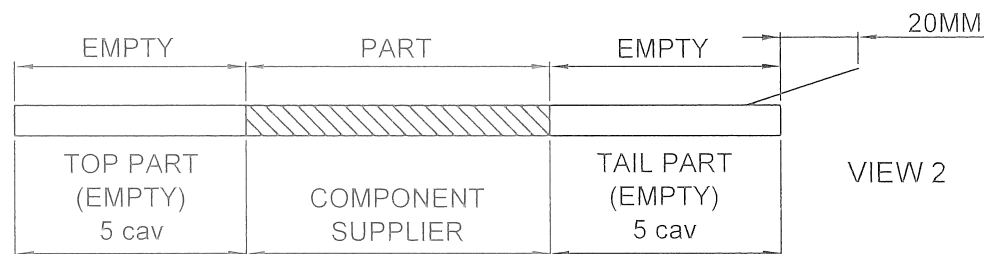

- 上带剥拉力为: 0.2~1.3N(20gf~130gf)
Peeling off force of top tape :0.2~1.3N(20gf~130gf)
出货运输过程中一定注意: 卷带在运输过程中不能散开
This requirement should be applied at shipment:
The reel tape can not be separated during transportation.

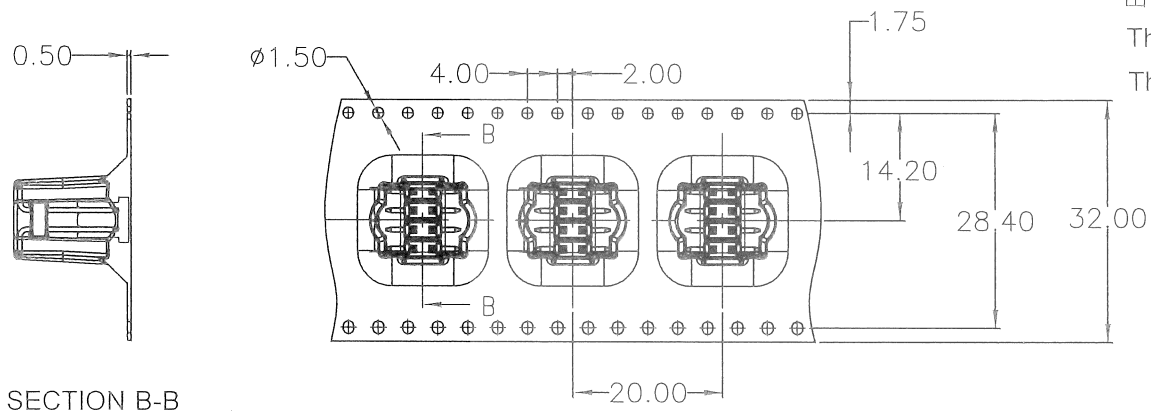

PLASTREN

TOLERANCE TABLE

X. ± 0.30	X.° ± 3°
.X ± 0.25	.X° ± 2°
.XX ± 0.20	

SCALE 1:1

UNIT mm

SIZE A4

DRAWN

李晨涛

DATE

2023/09/07

CHECK

何明

DATE

2023/09/07

APPROVE

朱文辉

DATE

2023/09/07

DWG. NO.

600-0000-2162

PARTS NO.(INTENDED USE)

BAHEA008RA00

TITLE

CUSTOMER DRAWING

REV.

7

SHEET

2/3

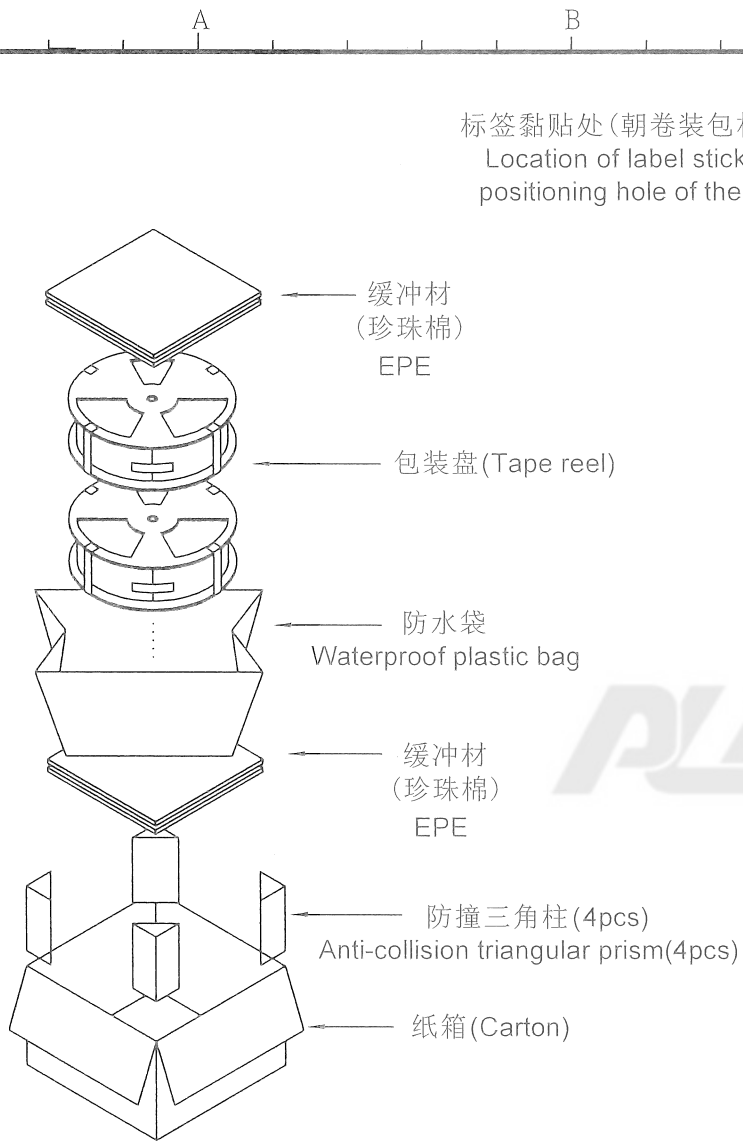

VIEW 4

标签黏贴处(朝卷装包材的小定位孔一侧)
Location of label sticking (label at small positioning hole of the carrier tape side)

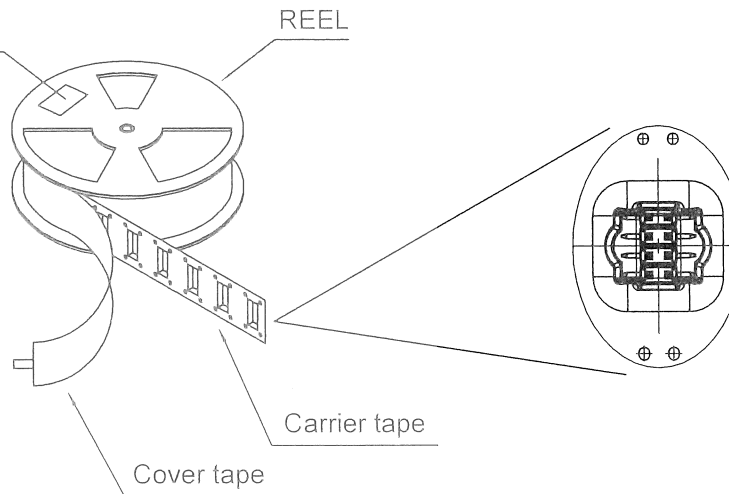

VIEW 5

备注 (NOTES):

- 每卷包装数量及每箱装箱数量如下表格。
Packing Q'ty of each reel & carton as below table shown.
- 上胶带覆盖下包装带用自粘包装。
Use cover tape to cover and seal up.
- 每个纸箱放2个珍珠棉。
Every carton use 2pcs EPE.
- 将装满产品的卷盘放入纸箱并以胶带封口。
Put reels in the carton and use adhesive tape to seal up.

产品料号 (Product No.)	包装数量 (Packing Quantity)		
	PCS/REEL	REELS/CARTON	PCS/CARTON
BAHEA008RA00	220	5	1100

	TOLERANCE TABLE		SCALE 1:1	DRAWN 李晨涛	DATE 2023/09/07	DWG. NO. 600-0000-2162	TITLE CUSTOMER DRAWING	REV. 7
	X. ± 0.30	X.° ± 3°	UNIT mm	CHECK 何志明	DATE 2023/09/07			PARTS NO.(INTENDED USE) BAHEA008RA00
	.X ± 0.25	.X.° ± 2°	SIZE A4	APPROVE 朱学梅	DATE 2023/09/07			
	.XX ± 0.20							