

RECOMMENDED PCB LAYOUT  
(PCB TOLERANCE ±0.05)

版次	ECN 编码	描述		设计/日期
1	EH19100044	初版发行		齐如军_2019/11/08
2	EL21040087	改前	改后	李思洁_2021/04/25
		额定电流0.5A	额定电流1.0A	

- NOTES: (Unless otherwise specified)
- Dimension shall be interpreted per ANSI Y14.5M.
  - Materials:  
Insulator material: High Temperature Thermoplastic, UL 94V-0; Color: Natural.  
Contact material: Copper alloy.
  - Current Rating: 1.0A.
  - Voltage Rating: 50V AC/DC.
  - Working Temperature: -40°C ~ +105°C.
  - Harmful material should be compliant to doc. "EI-0005" standards.
  - Product number matrix:

B E D A A X X X B X 00

Number of contacts  
030~080:30~80PIN  
100~140:100~140PIN  
B:MPAD+REEL

Plating Code:

Definition	Code	
● Tin plated	A	
● Gold plated(Function area)		
flash B 15u"	F	
10u"	E 30u"	
<td>● Duplex plated(Function area)</td> <td></td>	● Duplex plated(Function area)	
flash K 15u"	P	
10u"	N 30u"	
● Standard: B		

CIRCUITS	DIM.A	DIM.B	DIM.C
30	11.20	17.80	16.20
40	15.20	21.80	20.20
50	19.20	25.80	24.20
60	23.20	29.80	28.20
80	31.20	37.80	36.20
100	39.20	45.80	44.20
120	47.20	53.80	52.20
140	55.20	61.80	60.20

	TOLERANCE TABLE		SCALE 2:1	DRAWN 李思洁	DATE 2021/04/25	DWG. NO. 600-0000-2034	TITLE CUSTOMER DRAWING	REV. 2
	X ± 0.30	X° ± 3°	UNIT mm	CHECK 李思洁	DATE 2021/04/25	PARTS NO.(INTENDED USE)		SHEET 1/3
	.X ± 0.25	.X° ± 2°	SIZE A4	APPROVE 李思洁	DATE 2021/04/25	BEDAAXXXBX00		
	.XX ± 0.20							

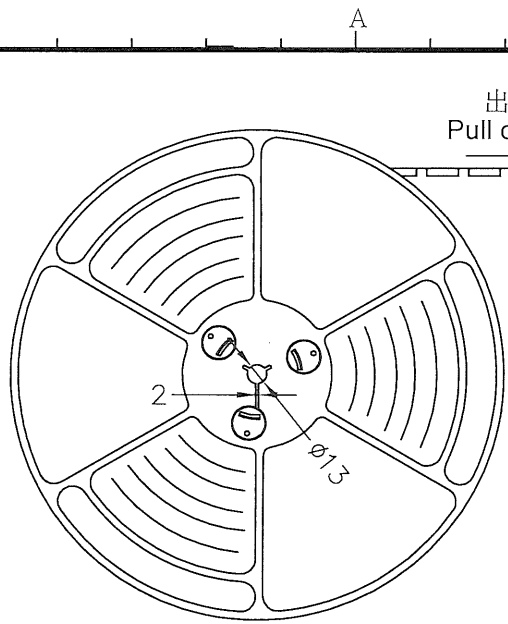

出料方向  
Pull out direction

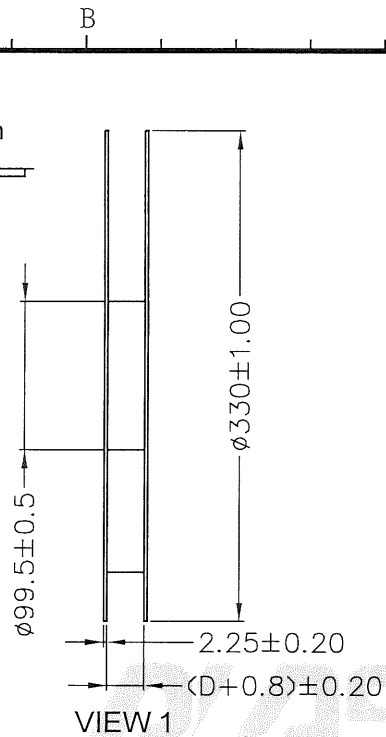

VIEW 1

备注 (NOTES):

1. 带子引导长度  
Lead tape length

转绕方向  
Pull out direction

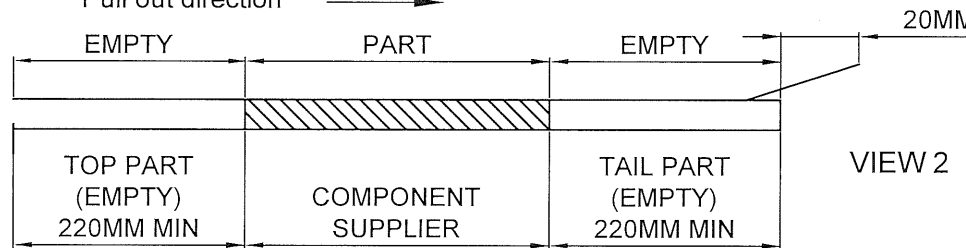

VIEW 2

2. 上带剥拉力为: 0.2~1.3N (20gf~130gf)

Peeling off force of top tape :0.2~1.3N(20gf~130gf)

出货运输过程中一定注意: 卷带在运输过程中不能散开

This requirement should be applied at shipment:

The reel tape can not be separated during transportation.

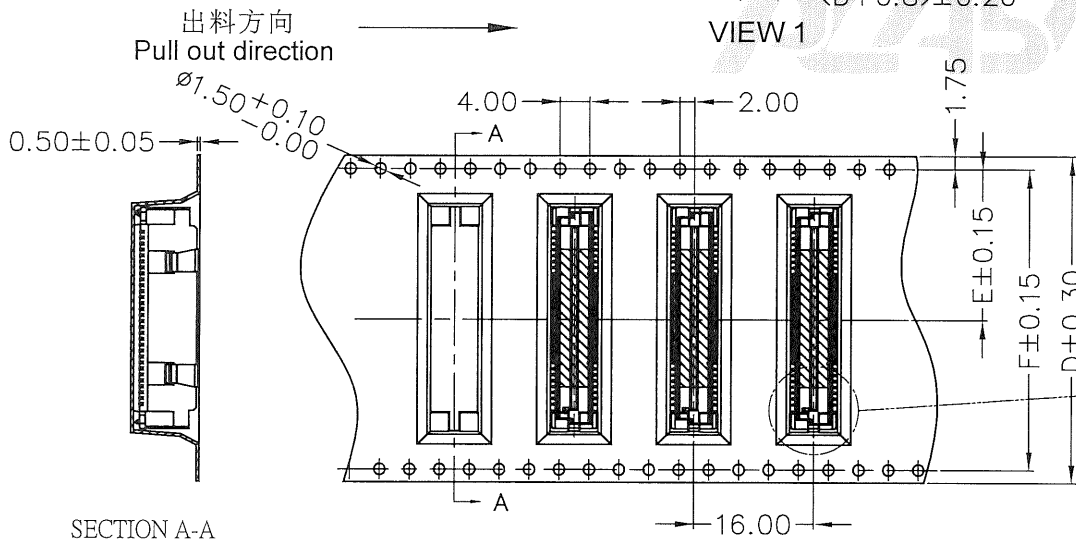

SECTION A-A

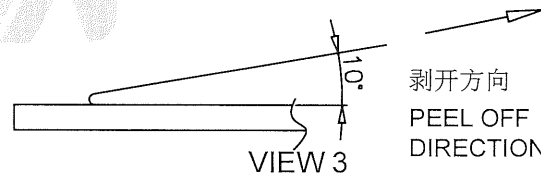

VIEW 3

剥开方向  
PEEL OFF DIRECTION

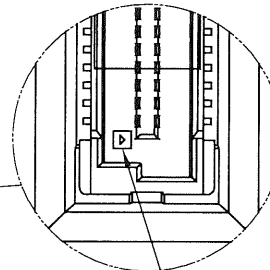

Loading direction mark

ITEM	P/N	DIM.F	DIM.E	DIM.D
REEL & FILM+REEL & MPAD+REEL	30PIN	40.40	20.20	44.00
	40PIN	40.40	20.20	44.00
	50PIN	40.40	20.20	44.00
	60PIN	40.40	20.20	44.00
	80PIN	52.40	26.20	56.00
	100PIN	68.40	34.20	72.00
	120PIN	68.40	34.20	72.00
140PIN	84.40	42.20	88.00	

	TOLERANCE TABLE		SCALE	1:1	DRAWN	李思洁	DATE	2021/04/25	DWG. NO.	600-0000-2034	TITLE	REV.
	X. ± 0.30	X.° ± 3°	UNIT	mm	CHECK		DATE	2021/04/25				PARTS NO.(INTENDED USE)
	.X ± 0.25	.X° ± 2°	SIZE	A4	APPROVE		DATE	2021/04/25	BEDAAXXB00	SHEET	2/3	
	.XX ± 0.20											

A B C D E

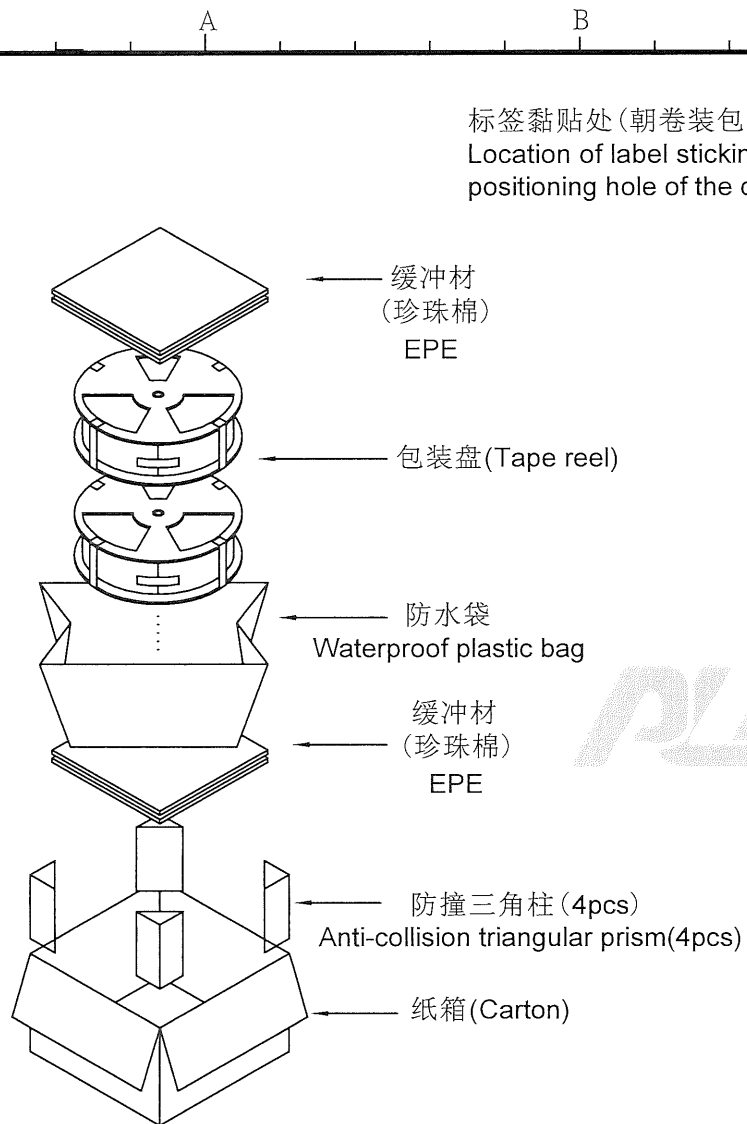

VIEW 4

标签黏贴处(朝卷装包材的小定位孔一侧)  
Location of label sticking (label at small positioning hole of the carrier tape side)

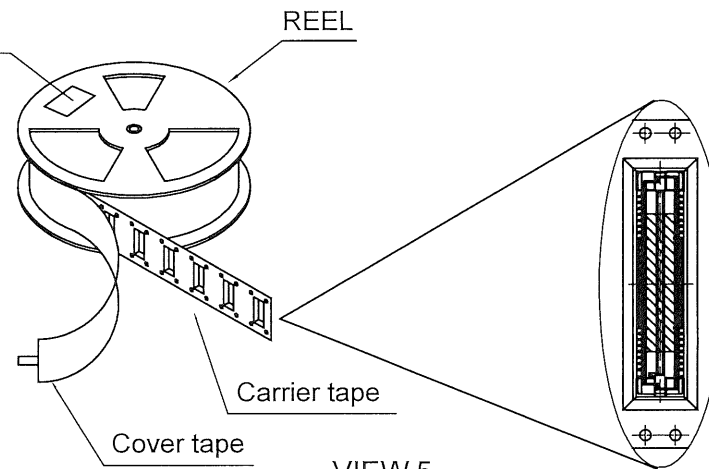

VIEW 5

备注(NOTES):

- 每卷包装数量及每箱装箱数量如下表格。  
Packing q'ty of each reel & carton as below table shown.
- 上胶带覆盖下包装带用自粘包装。  
Use cover tape to cover and seal up.
- 每个纸箱放2个珍珠棉。  
Every carton use 2pcs EPE.
- 将装满产品的卷盘放入纸箱以胶带封口。  
Put reels in the carton and use adhesive tape to seal up.

产品料号 (Product No.)	包装容量(Packing capacity)		
	PCS/REEL	REELS/CARTON	PCS/CARTON
BEDAA030BX00	400	4	1600
BEDAA040BX00	400	4	1600
BEDAA050BX00	400	4	1600
BEDAA060BX00	400	4	1600
BEDAA080BX00	400	3	1200
BEDAA100BX00	400	2	800
BEDAA120BX00	400	2	800
BEDAA140BX00	400	2	800



TOLERANCE TABLE	
X. ± 0.30	X.° ± 3°
.X ± 0.25	.X° ± 2°
.XX ± 0.20	

SCALE	1:1
UNIT	mm
SIZE	A4

DRAWN	李思洁
CHECK	李思洁
APPROVE	李思洁

DATE	2021/04/25
DATE	2021/04/25
DATE	2021/04/25

DWG. NO.	600-0000-2034
PARTS NO.(INTENDED USE)	BEDAAXXXBX00

TITLE	CUSTOMER DRAWING
-------	------------------

REV.	2
SHEET	3/3