

备注 (NOTES):

- 带子引导长度
Lead tape length
转绕方向
Pull out direction

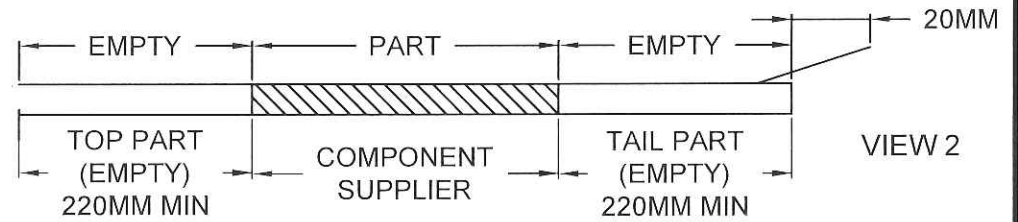

- 上带剥拉力为: 0.2~1.3N (20gf~130gf)
Peeling off force of top tape :0.2~1.3N(20gf~130gf)

出货运输过程中一定注意: 卷带在运输过程中不能散开
This requirement should be applied at shipment:
The reel tape can not be separated during transportation.

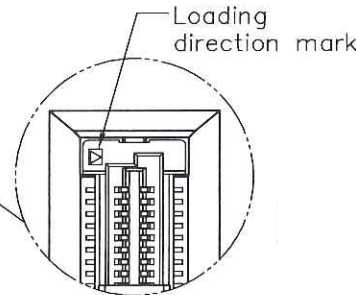
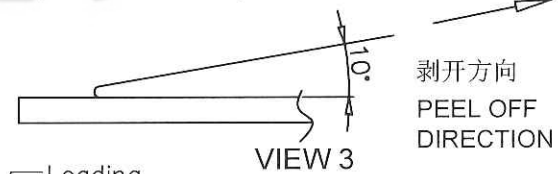
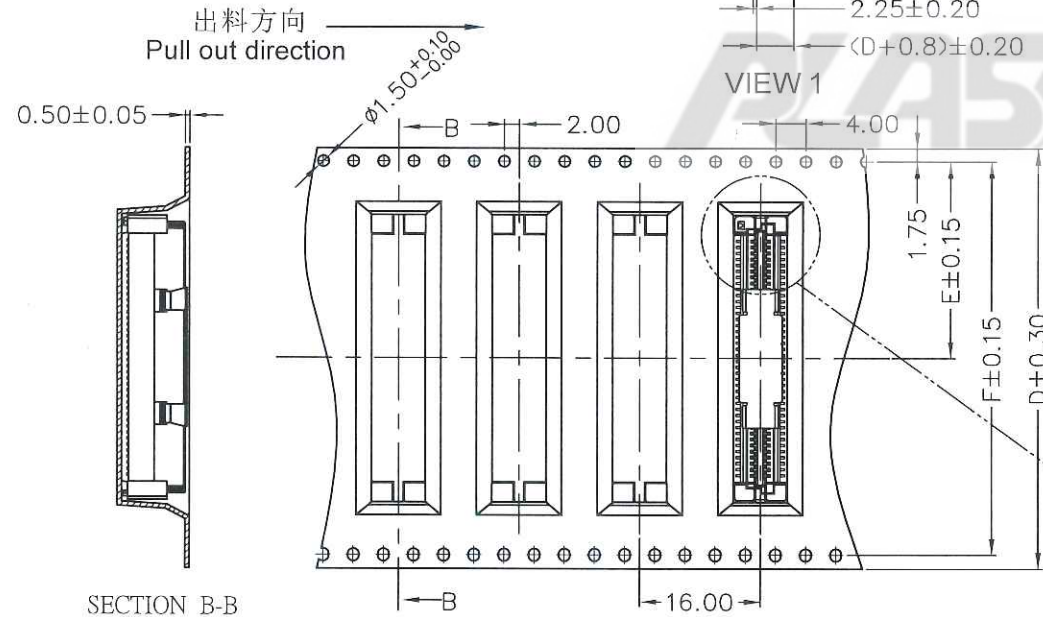

| ITEM | P/N | DIM.F | DIM.E | DIM.D |
|----------------------------------|--------|-------|-------|-------|
| REEL& FILM+REEL& MPAD+REEL | 30PIN | 40.40 | 20.20 | 44.00 |
| | 40PIN | 40.40 | 20.20 | 44.00 |
| | 50PIN | 40.40 | 20.20 | 44.00 |
| | 60PIN | 52.40 | 26.25 | 56.00 |
| | 80PIN | 52.40 | 26.25 | 56.00 |
| | 100PIN | 68.40 | 34.25 | 72.00 |
| | 120PIN | 68.40 | 34.25 | 72.00 |
| | 140PIN | 84.40 | 42.25 | 88.00 |



| TOLERANCE TABLE | |
|-----------------|----------|
| X. ± 0.30 | X.° ± 3° |
| .X ± 0.25 | .X° ± 2° |
| .XX ± 0.20 | |

| | | | | | |
|-------|-----|---------|-----|------|------------|
| SCALE | 1:1 | DRAWN | 齐如军 | DATE | 2019/11/08 |
| UNIT | mm | CHECK | 何国治 | DATE | 2019/11/11 |
| SIZE | A4 | APPROVE | 朱文祥 | DATE | 2019/11/11 |

| | |
|-------------------------|---------------|
| DWG. NO. | 600-0000-2022 |
| PARTS NO.(INTENDED USE) | DEBAAXXB00 |

| | |
|------------------|-------|
| TITLE | REV. |
| CUSTOMER DRAWING | 1 |
| | SHEET |
| | 2/3 |

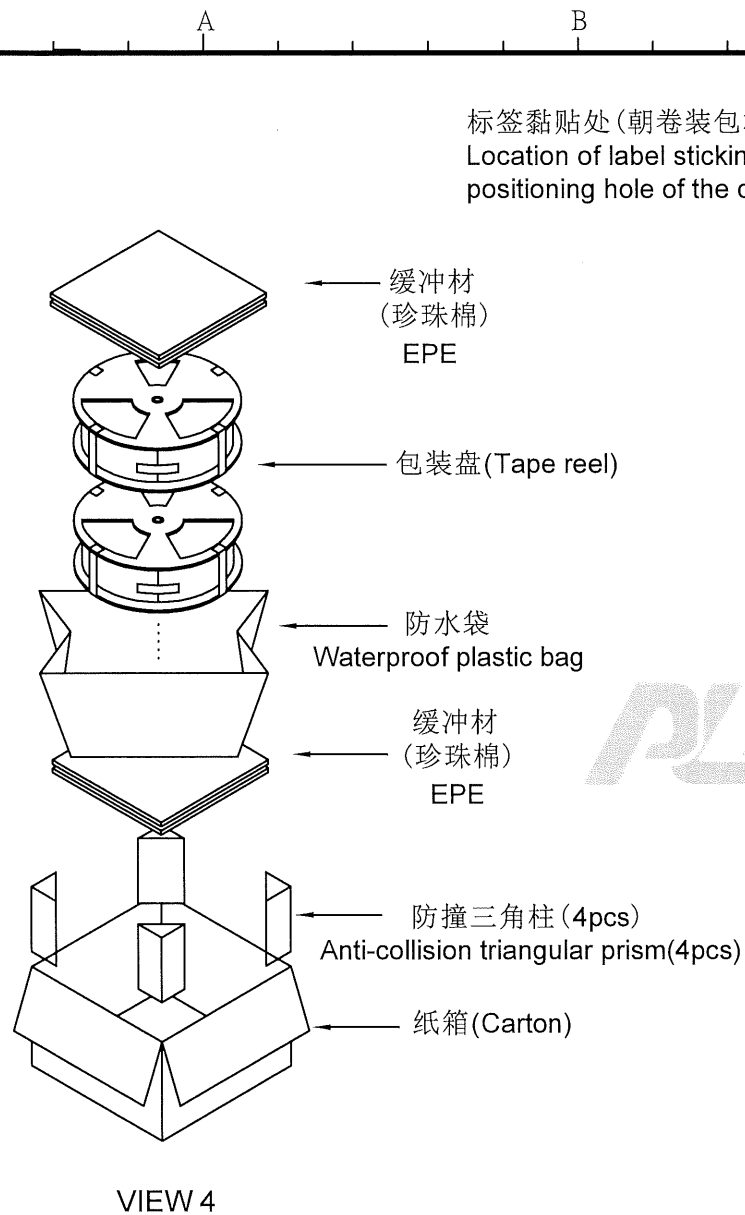

标签黏贴处 (朝卷装包材的小定位孔一侧)
Location of label sticking (label at small positioning hole of the carrier tape side)

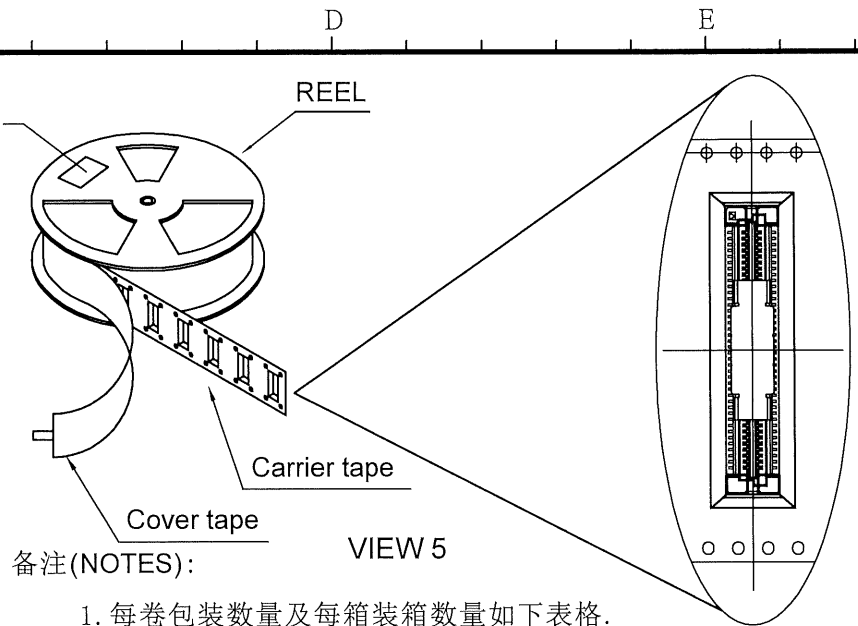

备注 (NOTES):

- 每卷包装数量及每箱装箱数量如下表格。
Packing q'ty of each reel & carton as below table shown.
- 上胶带覆盖下包装带用自粘包装。
Use cover tape to cover and seal up.
- 每个纸箱放2个珍珠棉。
Every carton use 2pcs EPE.
- 将装满产品的卷盘放入纸箱以胶带封口。
Put reels in the carton and use adhesive tape to seal up.

| 产品料号 (Product No.) | 包装容量 (Packing capacity) | | |
|-----------------------|-------------------------|--------------|------------|
| | PCS/REEL | REELS/CARTON | PCS/CARTON |
| DEBAA030BX00 | 400 | 4 | 1600 |
| DEBAA040BX00 | 400 | 4 | 1600 |
| DEBAA050BX00 | 400 | 4 | 1600 |
| DEBAA060BX00 | 400 | 3 | 1200 |
| DEBAA080BX00 | 300 | 3 | 900 |
| DEBAA100BX00 | 400 | 2 | 800 |
| DEBAA120BX00 | 300 | 2 | 600 |
| DEBAA140BX00 | 300 | 2 | 600 |

PLASTREN

TOLERANCE TABLE

| | |
|------------|----------|
| X. ± 0.30 | X.° ± 3° |
| .X ± 0.25 | .X° ± 2° |
| .XX ± 0.20 | |

SCALE 1:1

| | |
|------|----|
| UNIT | mm |
| SIZE | A4 |

DRAWN

齐如军

DATE

2019/11/08

CHECK

齐如军

DATE

2019/11/11

APPROVE

朱生祥

DATE

2019/11/11

DWG. NO.

600-0000-2022

PARTS NO. (INTENDED USE)

DEBAA030BX00

DEBAA030BX00

TITLE

CUSTOMER DRAWING

REV.

1

SHEET

3/3