

版次	ECN 编码	描述		设计/日期
1	EH19100039	初版发行		齐如军_2019/11/08
2	EL22100030	改前	改后	李晨涛_2022/10/12
		增加 D 尺寸		

- NOTES: (Unless otherwise specified)
- Dimension shall be interpreted per ANSI Y14.5M.
  - Materials:  
Insulator material: High Temperature Thermoplastic, UL 94V-0; Color: Natural.  
Contact material: Copper alloy.
  - Current Rating: 0.5A.
  - Voltage Rating: 50V AC/DC.
  - Working Temperature: -40°C ~ +105°C.
  - Harmful material should be compliant to doc. "EI-0005" standards.
  - Product number matrix:

DEDAAXXB00

Plating Code:

Definition	Code
● Tin plated	A
● Gold plated (Function area)	
flash B 15u" F	
10u" E 30u" J	
● Duplex plated (Function area)	
flash K 15u" P	
10u" N 30u" U	
● Standard: B	

Number of contacts  
030~080:30~80PIN  
100~140:100~140PIN  
B:MPAD+REEL

CIRCUITS	DIM.A	DIM.B	DIM.C	DIM.D
30	11.20	17.80	16.20	13.25
40	15.20	21.80	20.20	17.25
50	19.20	25.80	24.20	21.25
60	23.20	29.80	28.20	25.25
80	31.20	37.80	36.20	33.25
100	39.20	45.80	44.20	41.25
120	47.20	53.80	52.20	49.25
140	55.20	61.80	60.20	57.25

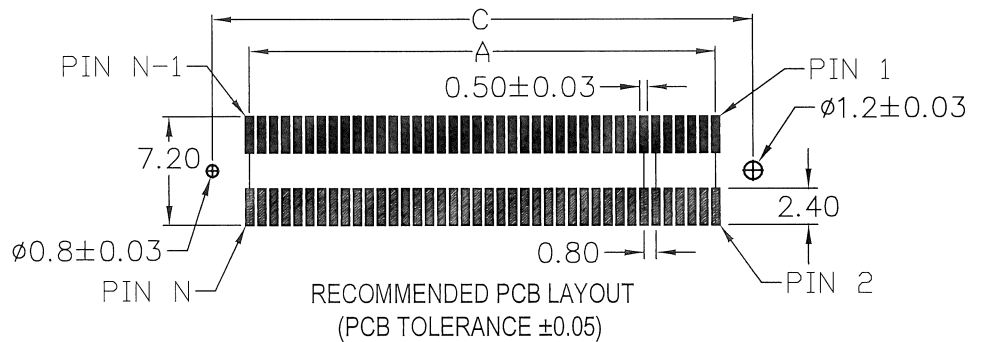

	TOLERANCE TABLE		SCALE 2:1	DRAWN 李晨涛	DATE 2022/10/12	DWG. NO. 600-0000-1990	TITLE	REV. 2
	X. ± 0.30	X.° ± 3°	UNIT mm	CHECK 李晨涛	DATE 2022/10/26	PARTS NO.(INTENDED USE) DEDAAXXB00	CUSTOMER DRAWING	SHEET 1/3
	.X ± 0.25	.X° ± 2°	SIZE A4	APPROVE 李晨涛	DATE 2022/10/26			
	.XX ± 0.20							

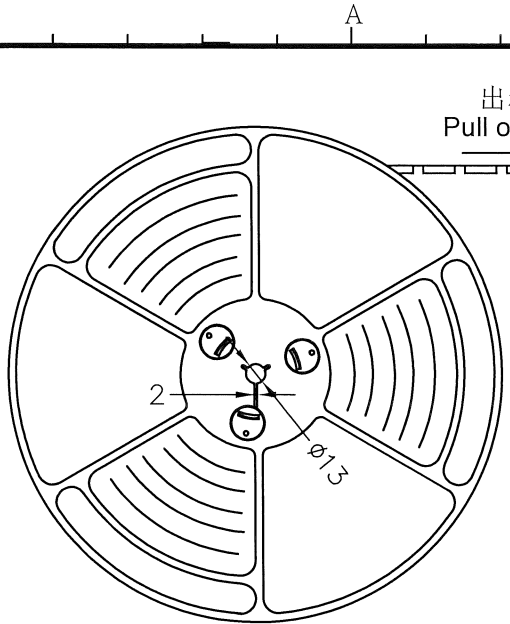

出料方向  
Pull out direction

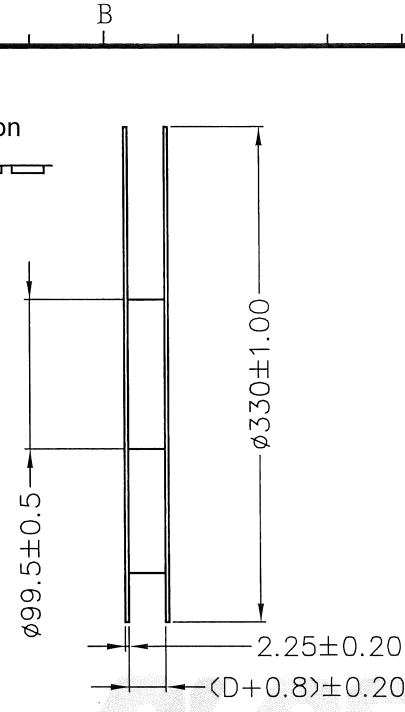

VIEW 1

备注 (NOTES):

1. 带子引导长度  
Lead tape length

转绕方向

Pull out direction

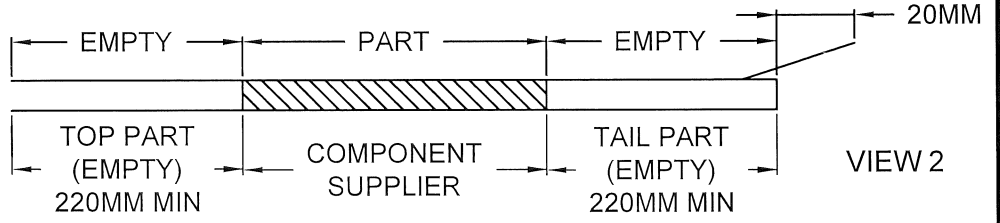

VIEW 2

2. 上带剥拉力为: 0.2~1.3N(20gf~130gf)

Peeling off force of top tape :0.2~1.3N(20gf~130gf)

出货运输过程中一定注意: 卷带在运输过程中不能散开

This requirement should be applied at shipment:

The reel tape can not be separated during transportation.

出料方向  
Pull out direction

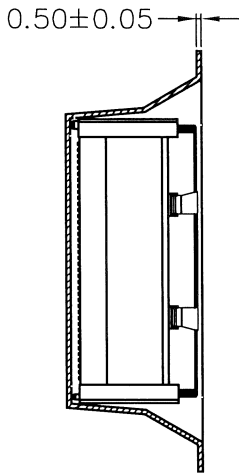

SECTION B-B

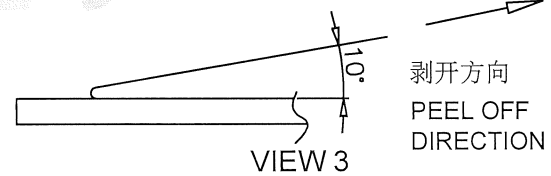
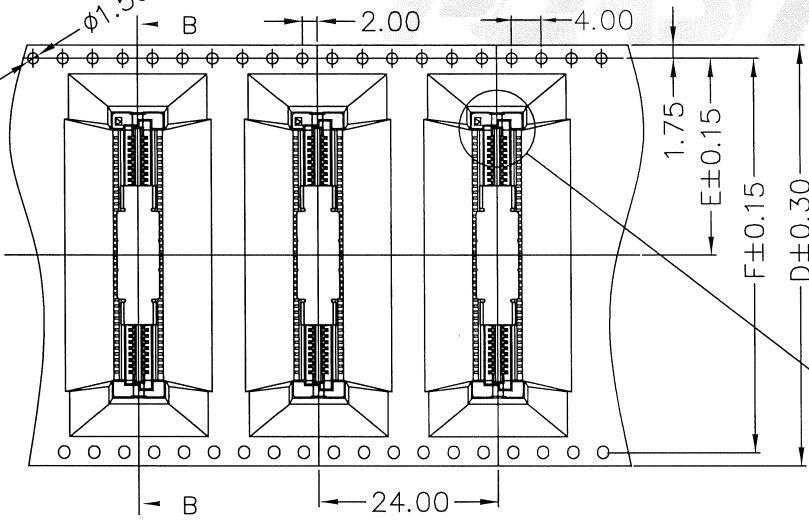

VIEW 3

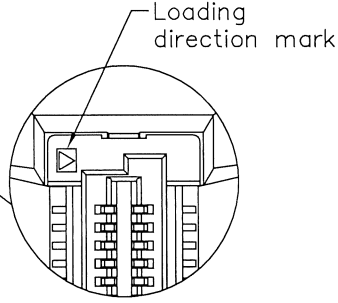

ITEM	P/N	DIM.F	DIM.E	DIM.D
REEL & FILM+REEL & MPAD+REEL	30PIN	40.40	20.20	44.00
	40PIN	40.40	20.20	44.00
	50PIN	40.40	26.20	44.00
	60PIN	52.40	26.20	56.00
	80PIN	68.40	26.20	72.00
	100PIN	68.40	34.20	72.00
	120PIN	84.40	42.20	88.00
	140PIN	84.40	42.20	88.00



TOLERANCE TABLE	
X. $\pm$ 0.30	X.° $\pm$ 3°
.X $\pm$ 0.25	.X° $\pm$ 2°
.XX $\pm$ 0.20	

SCALE	1:1
UNIT	mm
SIZE	A4

DRAWN	李晨涛
CHECK	12/20/26
APPROVE	李晨涛

DATE	2022/10/12
DATE	2022/10/26
DATE	2022/10/26

DWG. NO.	600-0000-1990
PARTS NO.(INTENDED USE)	DEDAAXXBX00

TITLE	CUSTOMER DRAWING
-------	------------------

REV.	2
SHEET	2/3

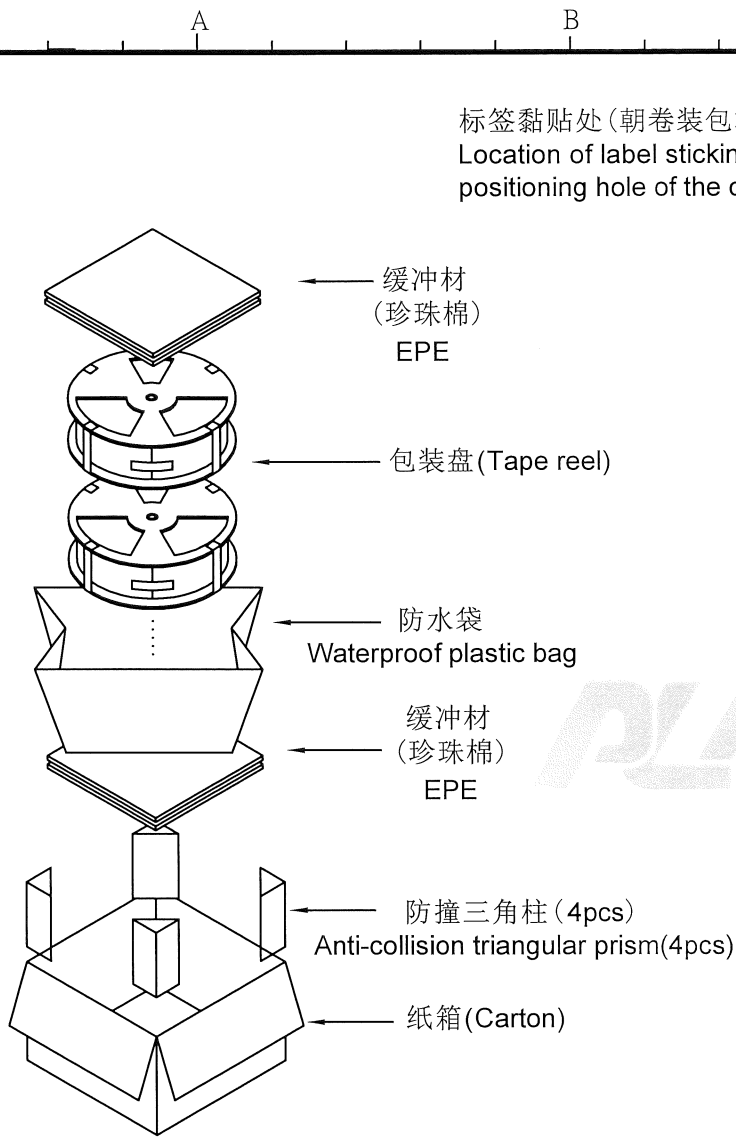

VIEW 4

标签黏贴处(朝卷装包材的小定位孔一侧)  
Location of label sticking (label at small positioning hole of the carrier tape side)

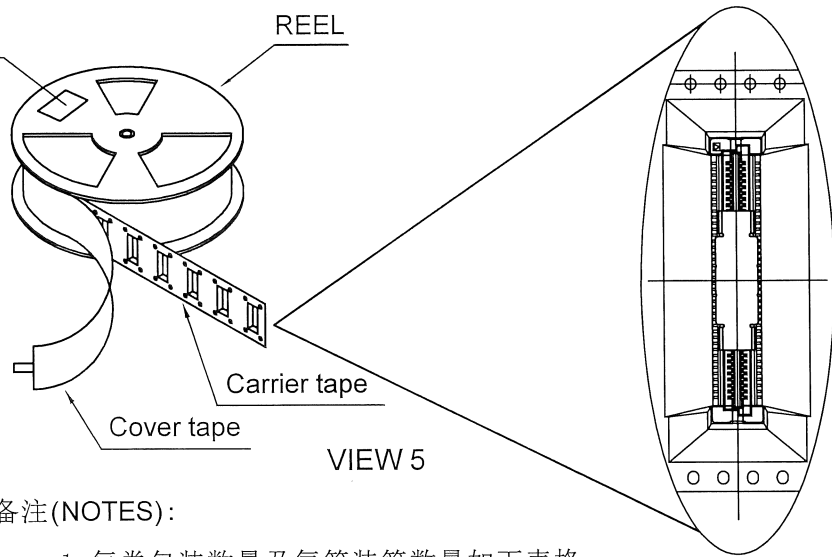

VIEW 5

备注(NOTES):

1. 每卷包装数量及每箱装箱数量如下表格。  
Packing q'ty of each reel & carton as below table shown.
2. 上胶带覆盖下包装带用自粘包装。  
Use cover tape to cover and seal up.
3. 每个纸箱放2个珍珠棉。  
Every carton use 2pcs EPE.
4. 将装满产品的卷盘放入纸箱以胶带封口。  
Put reels in the carton and use adhesive tape to seal up.

产品料号 (Product No.)	包装容量(Packing capacity)		
	PCS/REEL	REELS/CARTON	PCS/CARTON
DEDA030BX00	150	4	600
DEDA040BX00	150	4	600
DEDA050BX00	150	4	600
DEDA060BX00	150	3	450
DEDA080BX00	150	2	300
DEDA100BX00	100	2	200
DEDA120BX00	150	2	300
DEDA140BX00	150	2	300

	TOLERANCE TABLE		SCALE 1:1	DRAWN 李晨涛	DATE 2022/10/12	DWG. NO. 600-0000-1990	TITLE CUSTOMER DRAWING	REV. 2
	X. ± 0.30	X.° ± 3°	UNIT mm	CHECK <i>李晨涛</i>	DATE 2022/10/26			PARTS NO.(INTENDED USE) DEDAAXXXBX00
	.X ± 0.25	.X° ± 2°	SIZE A4	APPROVE <i>李晨涛</i>	DATE 2022/10/26			
	.XX ± 0.20							