

版次	ECN 编码	描述		设计/日期
1	EL20110036	初版发行		苏琴_2020/09/13
2	EL21050045	改前	改后	苏琴_2021/05/27
		7200PCS	16200PCS	
3	EL21080077	增加保持力规格		李思洁_2021/08/31
4	EL22110048	0.63 ^{+0.01} _{-0.03}	0.64 ^{+0.01} _{-0.03}	李晨涛_2022/11/12
		Ni: 80~160u"	Ni: 50u" Min	
5	EL23070056	16200PCS	13200PCS	江蒙_2023/07/19

- NOTES: (Unless otherwise specified)
- Dimensions shall be interpreted per ANSI Y14.5M.
 - Materials:
Insulator material: High Temperature Thermoplastic, UL 94V-0; Color: Black.
Contact material: Copper alloy.
 - Current Rating: 3A per pin.
 - Voltage Rating: 250V AC/DC.
 - Working Temperature: -55°C ~ +125°C.
 - Contact retention force: 1000g Min per contact.
 - Harmful material should be compliant to doc. "EI-0005" standards.
 - Product number matrix:

A A A B J 004 G A 0 0

G: TUBE

Plating Code:

Surface area: Plating matte Sn 120-240u".
The bottom layer: Plating Ni 50u" Min.

RECOMMENDED PCB LAYOUT
(PCB TOLERANCE ±0.05)

	TOLERANCE TABLE		SCALE 4:1	DRAWN 江蒙	DATE 2023/07/19	DWG. NO. 600-0000-2141	TITLE	REV. 5
	X. ± 0.30	X.° ± 3°	UNIT mm	CHECK 朱宇梅	DATE 2023/07/29	PARTS NO.(INTENDED USE) AAABJ004GA00	CUSTOMER DRAWING	SHEET 1/2
	.X ± 0.25	.X° ± 2°	SIZE A4	APPROVE 傅文超	DATE 2023/07/29			
	.XX ± 0.20							

- 一.
- 1) TUBE一端先以橡皮塞封住,將成品依序放入包裝管。(包裝數量見包裝明細)
One end of the tube is sealed with soft stopper, then put the products into tube in seriate order.
(The quantity per tube see the detail of the packing)

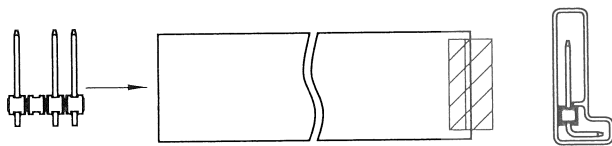

VIEW 1

- 二.
- 1) 將包裝管兩側用軟塞塞緊。
Seal the sides of the tube with soft stopper.

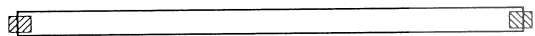

VIEW 2

三.

- 1) 包裝管每10支用橡皮筋綁成一卷, 兩端以保鮮膜纏繞, 將標籤貼于同一方向。
Each the tubes are tied with a rubber band, Both ends wrapped with plastic wrap, Stick the label in the same direction.
- 2) 包裝管放入防水袋中后用膠帶貼實封口。
Put the tubes into the waterproof bag and sealed with tape.
- 3) 一只紙箱包裝數量請見包裝明細。
The quantity of the products per carton please follow the detail of the packing.

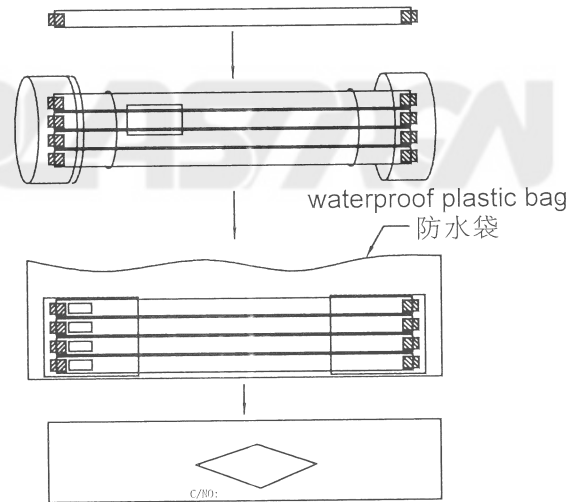

VIEW 3

四.

- 1) 將標籤貼于指定的標籤黏貼處。
Stick the label on the "Stick Label Area"

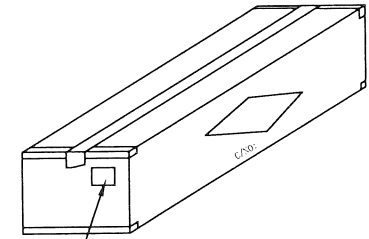

標籤黏貼處
Stick Label Area

VIEW 4

备注(NOTES):

1. 若有未裝滿之零數箱, 必須以緩沖材塞滿。
If the product's Q'ty is under MPQ, the carton must be filled with buffer material.
2. 裝滿成品后之外箱, 最大堆積箱數: 5箱。
The max. pile up number of packed carton is 5.
3. 具體包裝數量請參照包裝明細。
Please refer to the packing list for the actual packing details.
4. 如須貼Bar-code, 請依Bar-code作業辦法執行。
If barcode is needed, please follow Barcode SOP.

產品料号 (Product No.)	包裝數量 (Packing Quantity)		
	PCS/TUBE	TUBES/CARTON	PCS/CARTON
AAABJ004GA00	60	220	13200



TOLERANCE TABLE	
X. ± 0.30	X.° ± 3°
.X ± 0.25	.X° ± 2°
.XX ± 0.20	

SCALE	1:1
UNIT	mm
SIZE	A4

DRAWN	江蒙
CHECK	李昌洋
APPROVE	朱光輝

DATE	2023/07/19
DATE	2023/07/28
DATE	2023/07/29

DWG. NO.	600-0000-2141
PARTS NO.(INTENDED USE)	AAABJ004GA00

TITLE	CUSTOMER DRAWING
-------	------------------

REV.	5
SHEET	2/2